

Trade of Electrician

Standards Based Apprenticeship

Lighting Circuits

Phase 2

Module No. 2.2

Unit No. 2.2.2

COURSE NOTES

Created by Chris Ludlow - Dundalk TC

Revision 1 April 2000 By
Chris Ludlow - Dundalk TC
Eugene Trindles - Cork TC

Revision 2 Nov 2002 By
Chris Ludlow - Dundalk TC
Charlie Walsh - Athlone TC

Revision 3 May 2006 By
Chris Ludlow - Dundalk TC

Revision 4. Feb 2008 By
Chris Ludlow - Dundalk TC

Revision 5. July 2009 By
Chris Ludlow - Dundalk TC

Revision 6. October 2009 By
Chris Ludlow - Dundalk TC

Revision 7, November 2013
SOLAS

Compiled by Liam Carroll – Certification & Standards

Published by

SOLAS

An tSeirbhís Oideachais Leanúnaigh agus Scileanna
Further Education and Training Authority

27-33 Upper Baggot Street
Dublin 4
Ireland

© SOLAS - 2013

All rights reserved. No part of this publication may be reproduced, stored in a retrieval system or transmitted in any form or by any means, electronic, mechanical, photocopying, recording or otherwise, without the prior permission of the copyright owner.

Table of Contents

INTRODUCTION	4
GRAPHICAL SYMBOLS	5
DEFINITIONS.....	8
SEQUENCE OF CONTROL.....	9
DOMESTIC INSTALLATION TYPES	10
SURFACE MOUNTED INSTALLATION	11
SWITCHES.....	12
LAMPHOLDERS	17
BATTEN LAMPHOLDERS.....	18
CEILING ROSES	20
SWITCHING CIRCUITS.....	23
THE INCANDESCENT LAMP	29
DOMESTIC LIGHTING CIRCUITS.....	36
TIMESWITCH CONTROLLED LIGHTING.....	40
SMOKE ALARMS	42
TESTING LIGHTING CIRCUITS.....	44
MINI-TRUNKING SYSTEMS.....	46
DRY LINING BOXES.....	55
UNIT RELATED ETCI RULES	59

Introduction

Welcome to this section of your course which is designed to enable you the learner, install domestic lighting circuits.

Objectives

By the end of this unit you will be able to:









- Recognise and use important electrical symbols.
- Understand important terms associated with the installation of lighting circuits.
- Understand the sequence of control in a domestic installation.
- Explain the operation of 1 Way, Selective, 2 Way and Intermediate switches.
- Distinguish between different types of lampholders and ceiling roses.
- Install lampholders and ceiling roses.
- Install circuits involving 1 Way, Selective, 2 Way and 2 Way and Intermediate control.
- Install circuits using Loop-in and Three Plate Ceiling Rose systems.
- Understand how an incandescent lamp operates.
- List lamp wattages and recognise common bulb and cap types.
- Install a basic Smoke Alarm system.
- Test lighting circuit Polarity and Function.
- Install a minitrunking system using mitred joints.
- Select required minitrunking fittings and enclosures.
- Install a minitrunking system using fittings.
- Install drylining boxes in plasterboard.



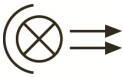

Reasons

Understanding this information will allow you read a drawing showing location of lighting accessories, switches etc. in a domestic installation. You will be able to read a circuit drawing showing lighting points controlled by 1 Way, Selective, 2 Way, and 2 Way and Intermediate switching.



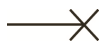

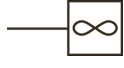





Graphical Symbols

Architectural

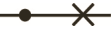
Distribution board	
One-Way Switch (Single Pole)	
Two-Way Switch (Single Pole)	
Intermediate Switch	
Lamp, general symbol	
Spotlight	
One Way Pull Cord Switch (Single Pole)	
One-Way Switch with Pilot Lamp (Single Pole)	
One-Way Period Limiting Switch (Single Pole)	

Lighting Outlet Position (Shown with Wiring)	
Lighting Outlet on Wall (Shown with Wiring)	
Fan (Shown with Wiring)	
Joint Box	
Time Switch	

Circuit

Fuse	
Isolator	
Fuse Isolator	
Fuse Switch	
Miniature Circuit Breaker (MCB)	
One-Way Switch (Single Pole)	
Two-Way Switch (Single Pole)	
Intermediate Switch	
Conductors Crossing (Not Connected)	
Conductors Crossing (Connected)	
Earth	

Definitions

Wiring System: An assembly made up of cables or busbars and the parts that secure, and if necessary enclose, the cables or busbars.

DSO: The distribution system operator.

Main Supply Point (origin of an installation): The point at which the supply is connected to an installation.

Nominal Voltage: A voltage by which an installation, or part of an installation, is designated.

Low Voltage: A nominal voltage exceeding 50 V AC or 120 V DC but not exceeding 1000 V AC or 1500 V DC.

Extra Low Voltage: A nominal voltage not exceeding 50 V AC or 120 V DC between conductors or between a conductor and earth.

Isolation (isolating function): Function intended to cut off the supply from all or a discrete section of the installation by separating the installation or section from every source of electrical energy for reasons of safety.

Isolating Switch: A mechanical switching device that, in the open position, complies with the requirements specified for the isolating function.

Main Isolating Switch: A switching device provided at the main supply point for the purpose of isolating an installation.

Switchgear: Equipment provided to be connected to an electrical circuit for the purpose of carrying out one or more of the following functions: protection, control, isolation, switching.

Distribution Board: An assembly of protective devices, including two or more fuses or circuit breakers, arranged for the distribution of electrical energy to final circuits or to other distribution boards.

Circuit: Part of an electrical installation supplied from the same origin and protected against overcurrents by a single protective device.

Current Using Equipment: Equipment intended to convert electrical energy into another form of energy, for example light, heat or motive power.

Final Circuit: A circuit connected directly to current using equipment or to socket outlets.

Point (in wiring): A termination of the fixed wiring intended for the connection of current-using equipment.

Luminaire: Apparatus that distributes, filters or transforms the light transmitted from one or more lamps and includes all the parts necessary for supporting, fixing and protecting the lamps and where necessary, circuit auxiliaries together with the means for connecting them to the supply. It does not include the lamps themselves.

Main Earthing Terminal (MET) or Bar: A terminal or bar provided for the connection of protective conductors, main equipotential bonding conductors and conductors for functional earthing if any, to the means of earthing.

Live Part: A conductor or conductive part intended to be energised in normal use, including a neutral conductor, but not a PEN conductor.

Sequence of Control

The electricity supply to a domestic installation begins at the meter cabinet which houses the DSO service fuse, DSO meter and an isolator. This is the **Main Supply Point**.

The DSO supply cable is referred to as the service cable. The DSO service fuse and meter are sealed to prevent any interference with this part of the installation. The **Nominal Voltage** of the supply to domestic premises is **230 Volts**. This is known as **Low Voltage**.

The control and distribution of the electricity supply to the installation is contained within one enclosure. It is referred to as a **Distribution Board**. This unit has its own **main switch fuse**, or a separate **main switch** and **main fuse**, or **main MCB**. This is followed by individual circuit fuses or more commonly nowadays, Miniature Circuit Breakers (MCB's), to protect and isolate each circuit. There will also be neutral and earth terminals provided. See Figure 1.

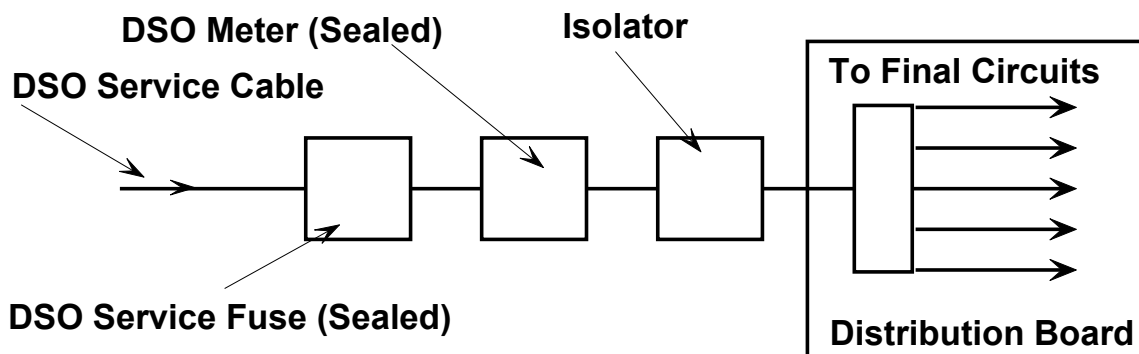

Figure 1.

The distribution board may also house other protective or control devices such as Residual Current Devices (RCD's), bell transformers, time-switches and contactors.

Figure 2 represents the sequence of control for a very basic distribution board. Depending on the installation requirements, a second or third RCD may be required and of course, more MCB's, one for each circuit.

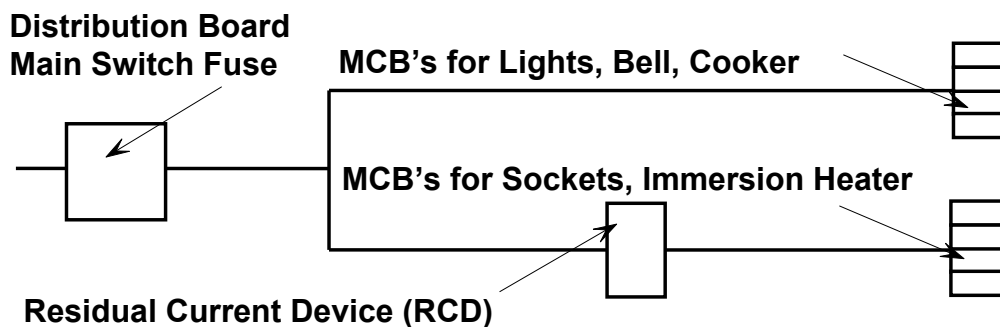

Figure 2.

As can be seen, an RCD is not provided for the lighting and cooker circuits, although there are exceptions to this situation.

Domestic Installation Types

Under the broad heading above, there are basically two types of installation involved:

1. Flush Mounted Installation
2. Surface Mounted Installation

Flush Mounted Installation

This is the most popular method of installation used in domestic premises, because all cables, switch boxes, socket boxes etc, are concealed in the walls, floors and ceilings.

The job of wiring a house is done in **two** distinct stages.

Stage One, referred to as the 'first fixing', involves:

- Chasing of walls to accept the necessary conduits (usually oval PVC type) and flush boxes for switches etc,
- Drilling of ceiling joists to allow cables be run in.
- Provision of battens to which ceiling roses can be mounted,
- Running in of all necessary cables.

After this stage nothing more can be done until all ceilings and walls are plastered and skimmed.

Stage Two, referred to as the 'second fixing' involves:

- Fitting and connecting of light switches, sockets, ceiling roses, lamp holders etc.
- Fitting and connecting of the distribution board.
- Identifying and marking all circuits.
- Testing the completed installation.

Flush mounted installations are covered in Phase 2 by the use of a simulated plasterboard partition to which certain flush mounted boxes can be attached. All other work will be as for a surface mounted installation.

Surface Mounted Installation

Surface mounted installations are used in various situations such as:-

- Extensions to an existing flush installation when interference with existing walls, floors or decor is not acceptable to the client.
- Rewiring of existing installations, again where walls, floors or decor cannot be interfered with or where cost is an important factor.
- Wiring of portable or prefabricated buildings.

A surface mounted installation in domestic / commercial situations normally involves the use of conduit or trunking. It is not unusual to see a combination of flush and surface work together, cables being concealed where possible and mounted on the surface where concealment is not possible.

PVC / PVC cables are normally used in surface mounted installations, as they can be installed directly on a surface, in a building void, in conduit, or in trunking.

Surface type boxes are used rather than flush types. Switches, sockets etc. are the same for both surface and flush types of installation.

Surface switch boxes are about **20mm deep** and white in colour, to match the type of switch used. The boxes have knock-outs for cable entry on all four sides and also in the base. These knockouts should be **carefully cut out using a junior hacksaw**, to suit the cable being installed. The boxes may be fixed directly to a surface using countersunk woodscrews placed through **slotted holes** for easy alignment, or directly to a round flush mounted conduit box.

Figure 3 illustrates a single surface mounted box, which can accommodate either 1, 2 or 3 gang switches. The double surface mounted box, shown in Figure 4, can accommodate either 4 or 6 gang switches.



Figure 3



Figure 4

Switches

The type of switch used in domestic installations is called a **plate switch**. Figure 5 illustrates a 1 gang 1 way plate switch. **One gang** refers to the fact that there is only one switch in the plate. **One-way** indicates that it is a one-way switch, two-way and intermediate switches are also available.



Figure 5

These switches are usually rated at 5 or 6 Amps, and intended for use on AC circuits only. They are **rocker type** switches and the operating principle of a 1 way single pole switch is shown in Figure 6.

Single pole means that there is only one contact. The contact must be used to break the phase conductor. If the number of poles is not mentioned for a particular switch, then it is assumed to be a single pole switch. Double pole switches are also available.

This type of switch has a centre-pivoted dolly. This dolly operates a contact, through a spring loaded, ball and socket mechanism. When the rocker is pressed to the 'down' position, the contact closes and when pressed to the 'up' position, the contact opens.

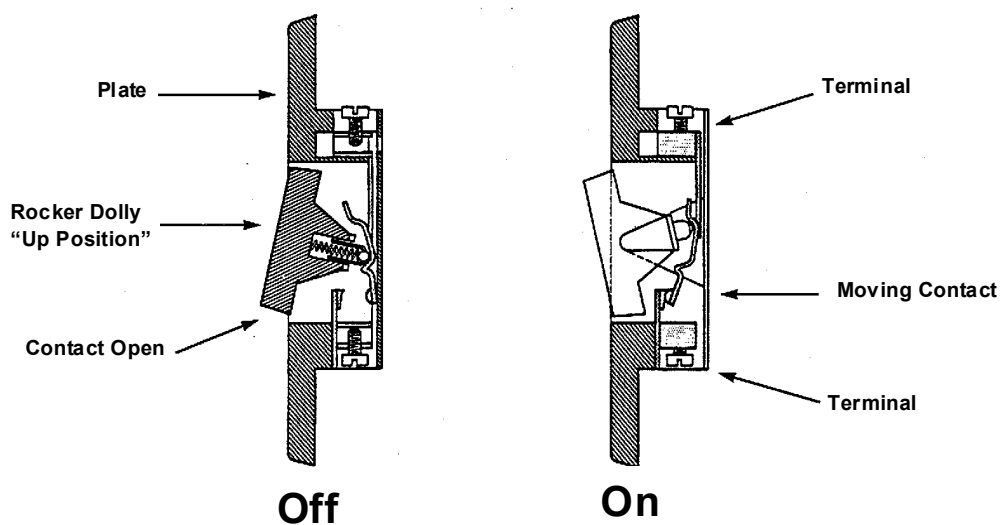
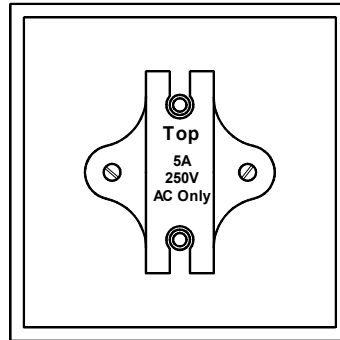

Figure 6.

Switch Terminal Identification

Figure 7 illustrates a 1 Gang 1 Way Single Pole switch, it has only two terminals. The phase conductor or **switch feed** is connected to the top terminal and the output conductor or **switch wire** is connected to the bottom terminal. If the opposite is done then the switch will still control the circuit. The switch should be fitted the right way up as indicated by the information on the back of the switch.



Typical Switch Markings (1Way)

Figure 7.

Figure 8 illustrates a 1 Gang 2 Way Single Pole switch, it has three terminals. The **switch feed** is normally connected to the common terminal and the switch will then give an output on either the L1 or L2 terminal. If there is more than one switch mounted on the plate, the wiring will be more complicated. It is best to simply identify each switch as a separate item.

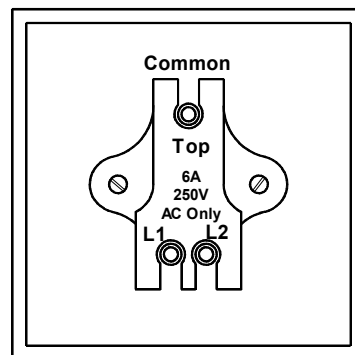

Switch Markings (2 Way)

Figure 8.

Figure 9 illustrates an intermediate switch, it has four terminals. This is a more complicated switch and will be dealt with later on.

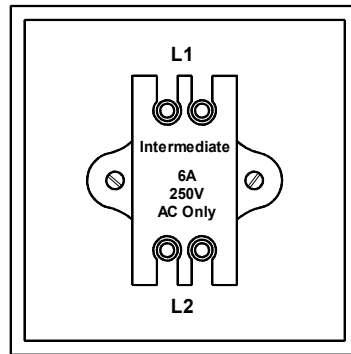

Switch Markings (Intermediate)

Figure 9.

Switch Gang and Way Identification

Figure 10 illustrates a 1 Gang Plate switch; it may be a 1 Way, 2 Way, intermediate or double pole type.

Example:

1 Gang 1 Way Plate Switch

1 Gang 2 Way Plate Switch

1 Gang Intermediate Plate Switch

1 Gang Double Pole Plate Switch



Figure 10.

Figure 11 illustrates a 2 Gang 2 Way Plate Switch. Two gang one way switches may not always be available, in this event two gang two way plate switches are generally used. This also applies to 3, 4 and 6 Gang switches.



Figure 11.

Figure 12 illustrates a 3 Gang 2 Way Plate Switch.



Figure 12.

Figure 13 illustrates a 4 Gang 2 Way Plate Switch; a double box is required for this switch. A 6 Gang 2 Way Plate Switch is also available

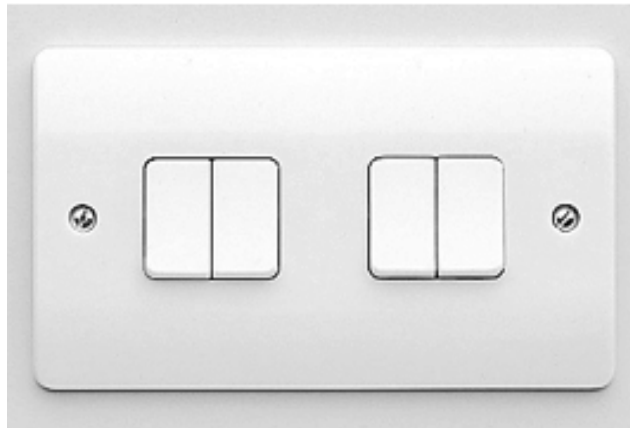

Figure 13.

Lampholders

Figure 14 illustrates a standard Bayonet Cap (BC) lampholder. BC lampholders are normally found in domestic installations. They are also available with a long shield. The shield, which is screwed on, is also used to retain any lampshade, which may be fitted.

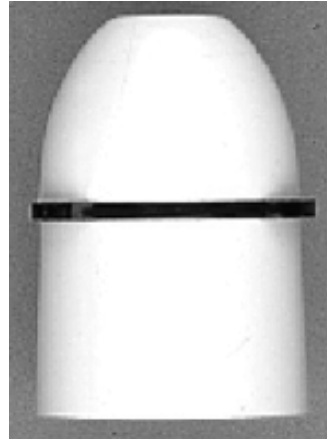

Figure 14.

Figure 15 illustrates a partly sectioned BC lampholder with the shield removed. BC lampholders are designed for quick and easy lamp removal and replacement. However, they must hold the lamp in firm electrical contact to prevent the lampholder from overheating. Connecting pins, which are spring loaded help, achieve this. A good cord grip is also an essential feature of lampholders and this must be properly utilised in order to take the strain of a possibly heavy lampshade, away from the flex terminations.

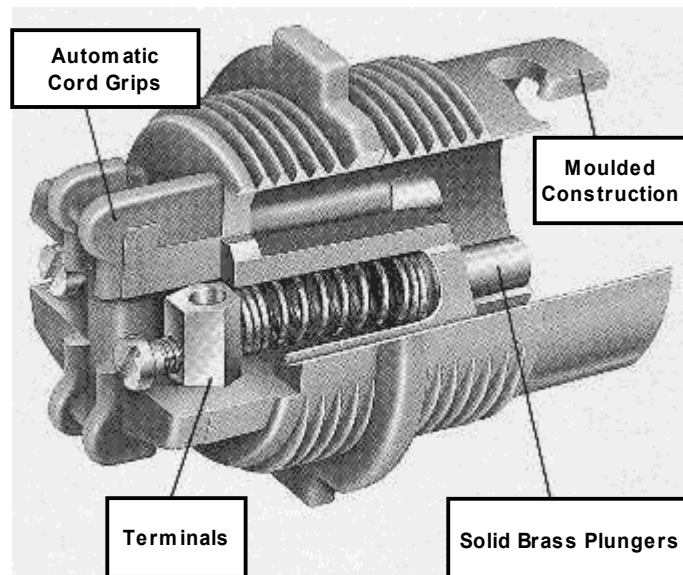

Figure 15.

Batten Lampholders

There are a variety of batten type lampholders on the market. The following is a sample of some of these.

Figure 16 illustrates a straight batten lampholder fitted with a 'short shield'. This shield provides protection against touching of the lamp cap. The batten lampholder has no backplate and therefore cannot be mounted directly on a surface without the use of a suitable base or box. Batten lampholders may have two or three terminals present.

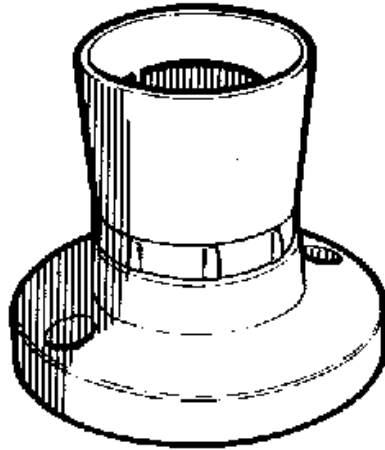

Figure 16.

Figure 17 illustrates an angle batten lampholder fitted with a long shield. It is also available with a short shield fitted. The long shield affords better protection against touching of the lamp. They have limited use in a modern installation.



Figure 17.

Figure 18 illustrates a mounting block for use with batten lampholders where necessary.



Figure 18.

Figure 19 illustrates a straight batten lampholder with an integral backplate fitted. This type of batten lampholder may have three or four terminals, and can be mounted directly on a surface. Cable entry is via the backplate.



Figure 19.

IMPORTANT: Batten lampholders, without an integral backplate, may **not** be mounted directly on a surface.

Ceiling Roses

There are basically two types of ceiling rose available, although there is a wide range of makes and shapes. The two types are the Two-Plate Ceiling Rose, which has two terminals and the Three-Plate Ceiling Rose, which has three terminals. Both were developed for use on different wiring systems. Older types of ceiling roses were developed at a time when it was not necessary to provide an earth at lighting points. It is now essential to provide an earth, and so an earth terminal is now included on all ceiling roses. This in effect means that a Two-Plate Ceiling Rose has a third terminal fitted, whilst a Three-Plate Ceiling Rose has four terminals.

Figure 20 illustrates one of the original types of Two-Plate Ceiling Rose. The earth terminal is marked "E" and the two unmarked terminals are used for the neutral and the switch wire. There must also be a cord grip provided similar to that in a lampholder.

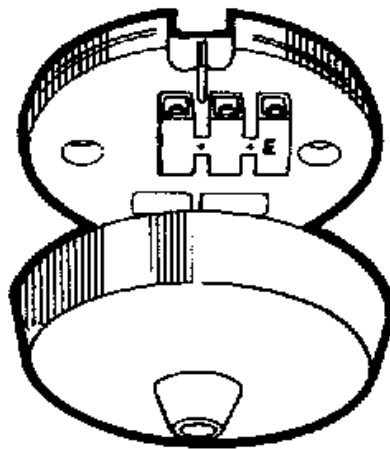

Figure 20

Figure 21 illustrates a Three-Plate Ceiling Rose. The additional terminal, marked L, is for the Phase or 'Live' conductor, which is present in a lighting system wired using the Three-Plate Ceiling Rose Method.

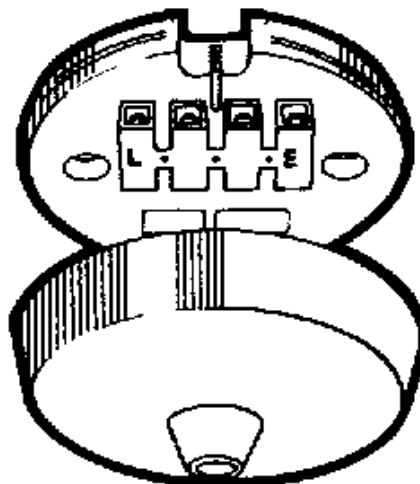

Figure 21.

Figure 22 illustrates a modern type Three-Plate Ceiling Rose which has been designed to minimise installation time, and maximise safety of the installer and the end user. Each of the four terminal blocks have three individual terminal screws. It caters for the connection of twelve conductors.

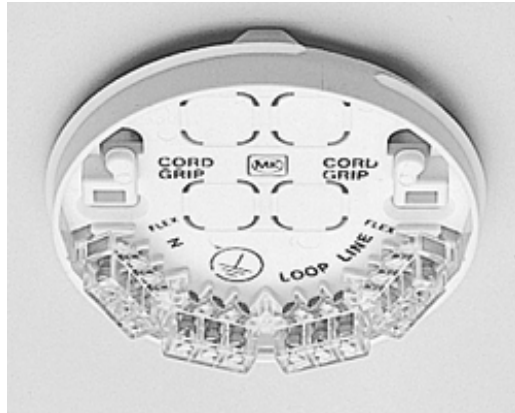

Figure 22.

Figure 23 illustrates a lampholder connected to a ceiling rose. The complete unit is called a pendant. The flex connecting the lampholder to the ceiling rose should be a minimum of 0.5mm^2 . Heat Resisting White Circular PVC type is recommended.

Pendants are available from certain manufacturers in a range of flex length. This allows installations to be completed more efficiently.



Figure 23.

Figure 24 illustrates a plug-in type ceiling rose and safety lampholder, which can be easily removed without leaving exposed conductors. The safety lampholder incorporates contacts, which are automatically disconnected from the supply, when the lamp is removed.

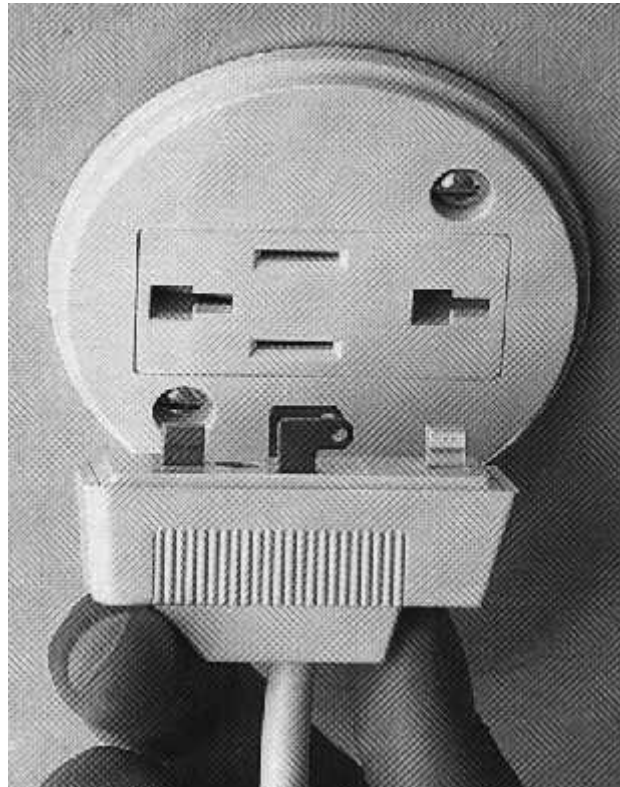

Figure 24.

The table below set out the maximum weight, which can be supported by some common, flex sizes.

Flex	Max. Weight
0.5mm ²	2 kg
0.75mm ²	3 kg
1.0mm ²	5 kg

Switching Circuits

One-Way Switching Circuit

Figure 25 shows how a lamp is controlled by a simple **one-way switch**, providing **on / off** control of the lamp. The phase conductor is connected to the one-way switch, terminal **C**, through a suitably rated fuse or MCB, 6-10A. The neutral is connected directly to the lamp.

When the switch is **closed** the phase conductor is **switched** through to the lamp from terminal **L1** and the 230 V supply is placed across the terminals of the lamp and so the lamp is illuminated.

When the switch is **opened** the phase conductor is **interrupted** and the lamp is extinguished. This occurs when the switch is in the “**up**” position.

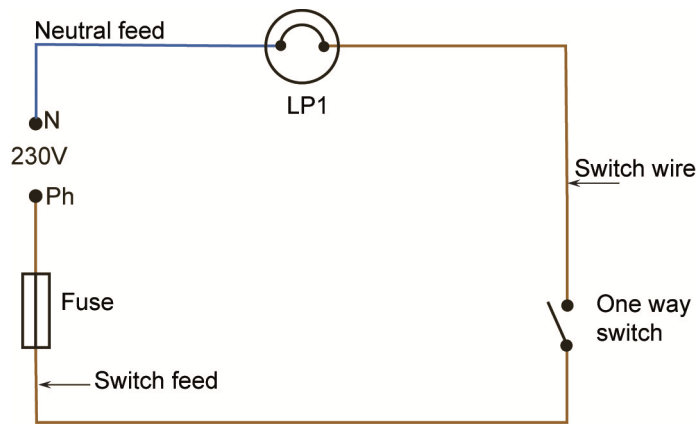

Figure 25.

If more than one lamp is required, the extra lamp or lamps should be connected in parallel as shown in Figure 26.

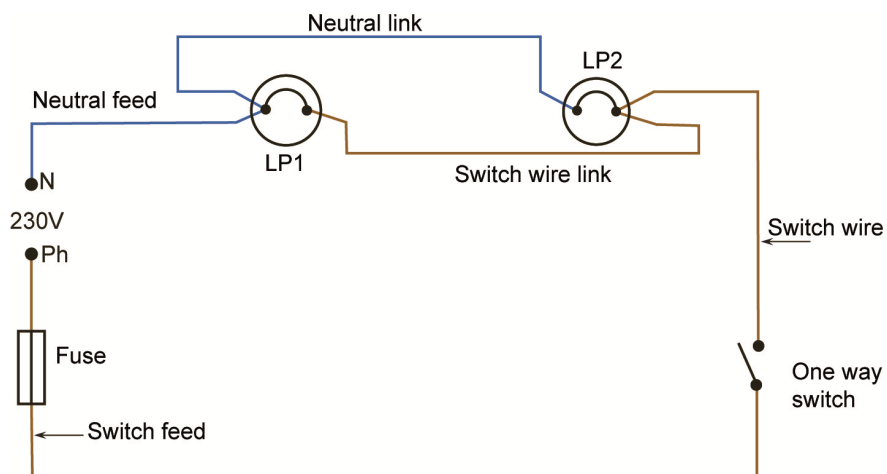

Figure 26.

Selective Switching Circuit

In Figure 27 a one-way switch is providing simple on / off control of the supply to a **selector switch**. This selector switch has two outputs. One of these outputs is used to feed lamp LP1, while the other feeds lamp LP2.

When the one-way switch is placed in the “**on**” position, either LP1 or LP2 will illuminate. When the selector switch is positioned as shown, LP1 will be “**on**” and LP2 will be “**off**”. If it is switched to the position shown by the dotted line, LP1 will be “**off**” and LP2 will be “**on**”.

In this way, one can select which lamp is “**on**” and which lamp is “**off**”. Both lamps cannot be “**on**” at the same time. This circuit was once used to provide two levels of lighting in certain circumstances. If LP1 were a 15 Watt lamp, it would provide a very low level of illumination in, say a child’s bedroom or a hospital ward. LP2 might, on the other hand, be a 100 Watt lamp and provide a high level of illumination.

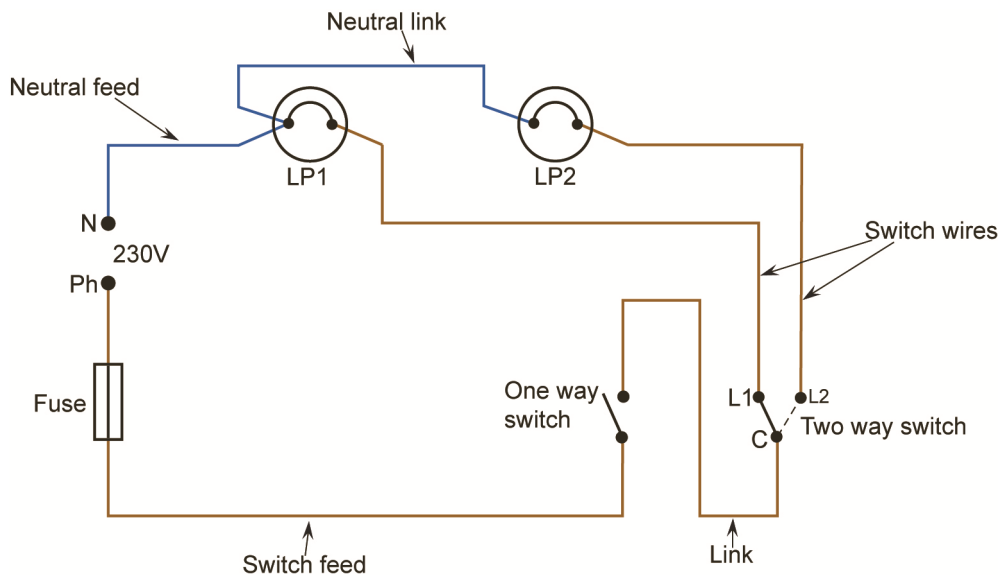

Figure 27.

Two-Way Switching Circuit

Figure 28 shows how a lamp can be controlled from two locations providing on / off control from either location. This circuit is used to control lamps in such places as stairways, corridors and rooms with two doorways.

The **two-way switch** has two outputs, sometimes labelled L1 and L2. The third terminal is referred to as the “**Common**” terminal and is marked “**C**” in some cases. This terminal is “**common**” to L1 & L2. In the “**up**” position the common is connected to L2 as shown, and therefore the lamp is “**off**”. If either switch is changed to the L1 position the lamp will be “**on**”. If both switches are changed to the L1 position the lamp will again be “**off**”. If the “**strappers**” are crossed over at either switch, the lamp will be “**on**” when both switches are in the “**up**” position. It is simply good practice to ensure that this does **not** occur. This means that it is possible to place all switches in the “**up**” position and be assured that all lamps are “**off**”. It also ensures safety when replacing faulty lamps or flex drops.

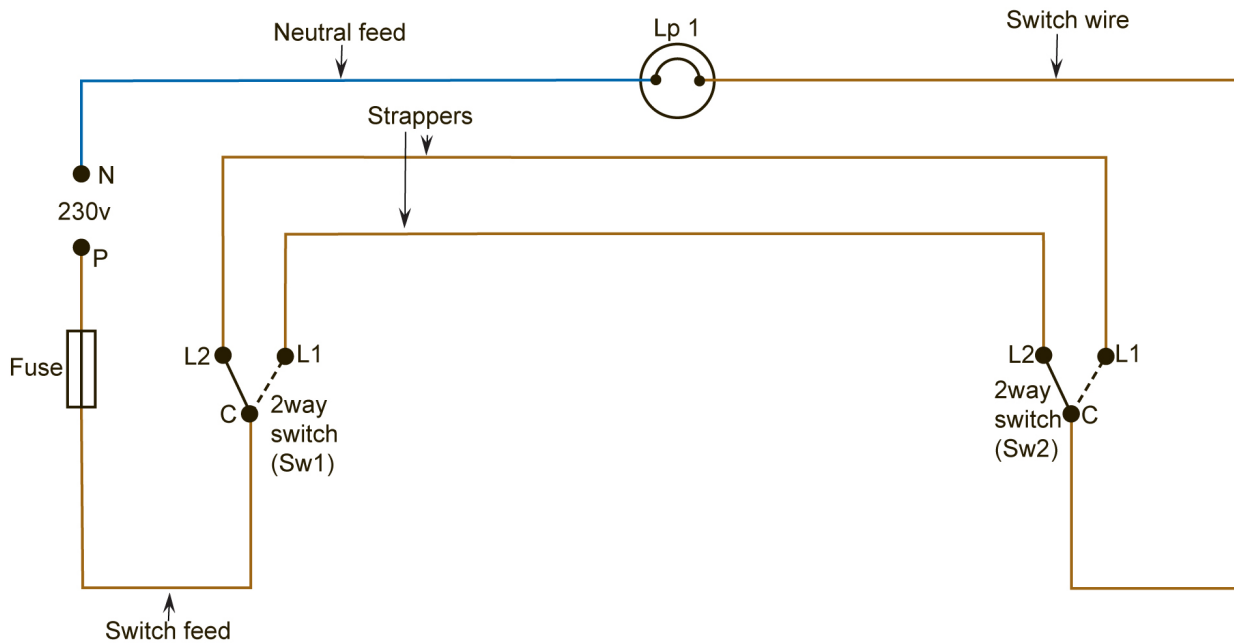

Figure 28

Figure 29 shows an alternative method of providing two-way switching. It is used to best advantage when a conversion from one-way to two-way control is required. Existing cables can be used without the unwanted extra connection at switch A, which would be required if the standard method was used.

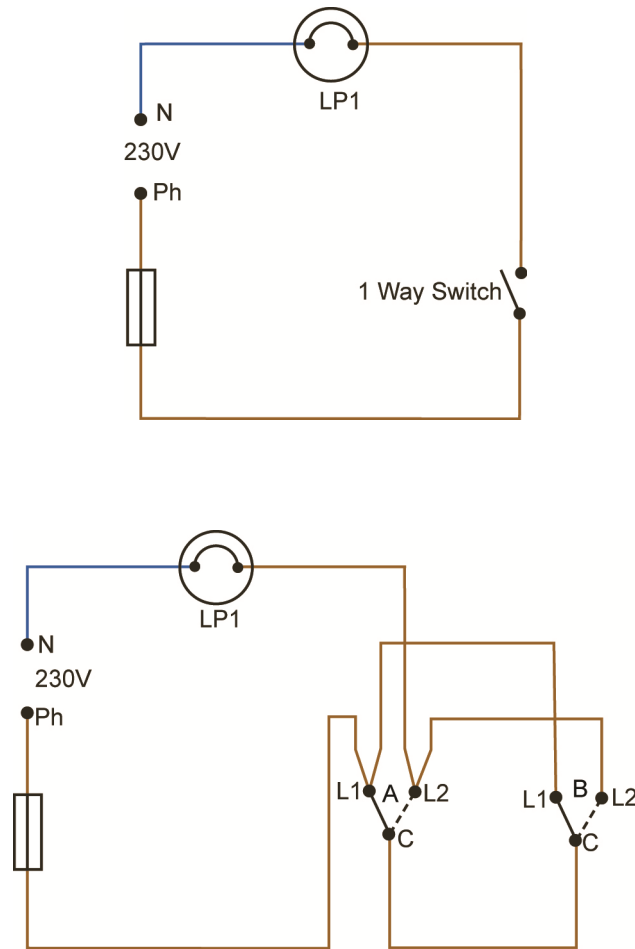

Figure 29

Two-Way and Intermediate Switching Circuit

Figure 30 shows how a lamp can be controlled from three locations, providing on / off control from each of these locations. This circuit is used to control lamps in such places as stairways with more than one landing, long corridors and rooms with more than two doorways. If more than three switching locations are required it is simply necessary to add in extra intermediate type switches, at these locations.

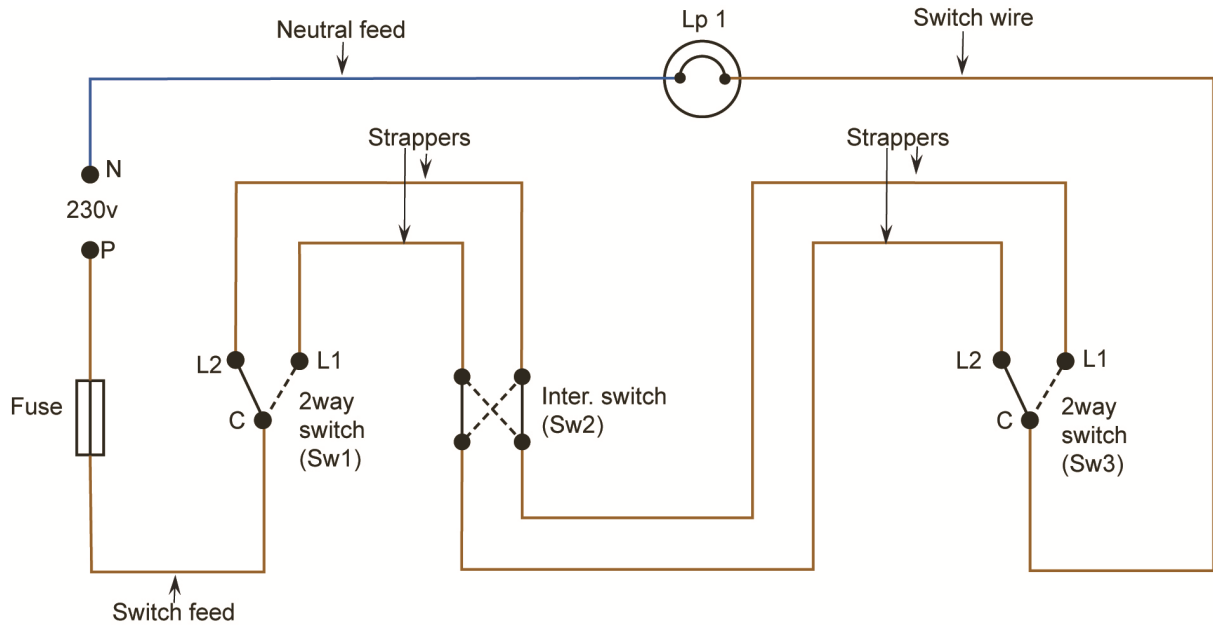

Figure 30.

The **intermediate switch** has four terminals. These terminals may be labelled in different ways, few of which are of any benefit to the installer. To complicate matters, there are two distinct types of intermediate switch. The more common type is shown in Figure 31. To consider how it functions we will number the terminals as follows:

In the **“up”** position terminals 1 and 2 are connected to terminals 3 and 4 respectively.
 In the **“down”** position terminals 1 and 2 are connected to terminals 4 and 3 respectively.
 See Figure 32.

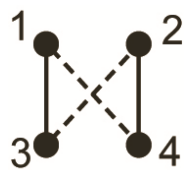

Figure 31

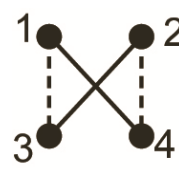

Figure 32

If we apply this information to the circuit above we can see that the lamp is **“off”**. By operating the intermediate switch, the lamp can be switched **“on”**. The two two-way switches operate as previously described. Other makes of intermediate switch may operate the opposite way round.

The other, less common type of intermediate switch operates as shown in Figure 33.

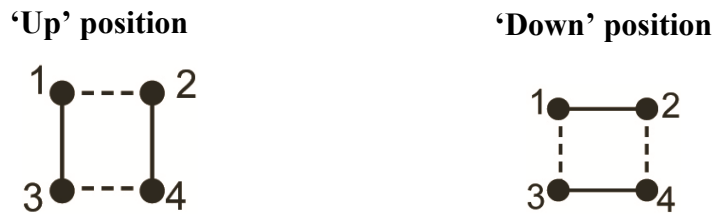

Figure 33

In the “up” position terminals 1 and 2 are connected to terminals 3 and 4 respectively. In the “down” position terminals 1 and 3 are connected to terminals 2 and 4 respectively.

This type of switch will be connected as shown in Figure 34.

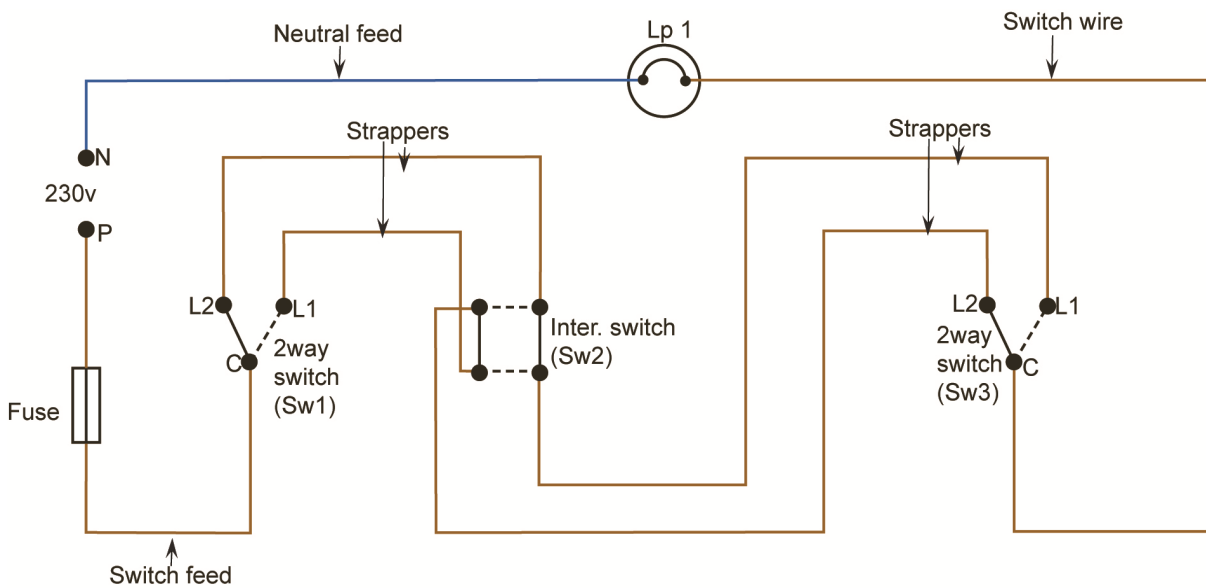

Figure 34

Again, if we apply the information regarding this type of intermediate switch, to the circuit shown in Figure 34, we can see that the lamp is “off”. By operating the intermediate switch, the lamp can be switched “on”. Alternate operating of the switches in any order will change the lamp condition i.e. “off” to “on” or “on” to “off”

It is obvious from Figure 34, that an intermediate switch has four terminals. It is important to remember that there are other types of switches, which have four terminals (e.g. double pole switches). The word “inter” or “intermediate” should be clearly marked on the back of an intermediate switch.

It is worth noting that a two-way switch or an intermediate switch can be used to complete the function of a one-way switch in a circuit. Also, an intermediate switch can be used instead of a two-way switch. This would only be done where the correct type of switch was not readily available.

The Incandescent Lamp

Lighting of the correct type and intensity is of great importance in both domestic and industrial environments as well as contributing to safety on our roads and streets.

The most commonly used lamp in domestic premises is known as the “**incandescent lamp**” or “**tungsten filament lamp**”. There are a number of these lamps in use and they are grouped together under the heading **General Lighting Service (GLS)** lamps.

These lamps operate on the principle that if a material is made “**white hot**” it will emit light. **Tungsten** is chosen for the **filament** because of the following two properties:

- It has a high melting temperature (3380°C)
- It can be drawn into very fine wire

This very fine wire is wound in the form of a coil (**single coil filament**). This process is taken a step further by coiling the coil (**coiled coil filament**), which improves the efficiency further, especially for the smaller ranges of lamp (below 150W).

See Figure 35

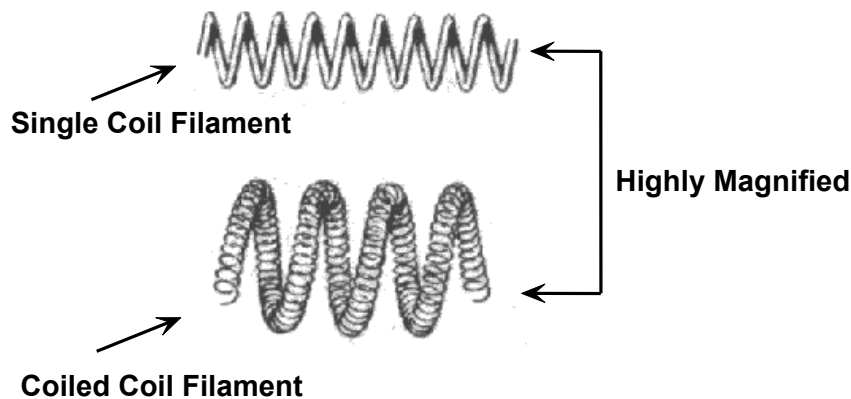

Figure 35

Figure 36 illustrates the filament supported on a **metal spider**, which is held by a **glass stem** and the whole arrangement is enclosed in a **glass envelope**, or **bulb**. The **filament fuse** is a valuable feature as it avoids possible disruptive arcing and the blowing of circuit fuses when a lamp fails.

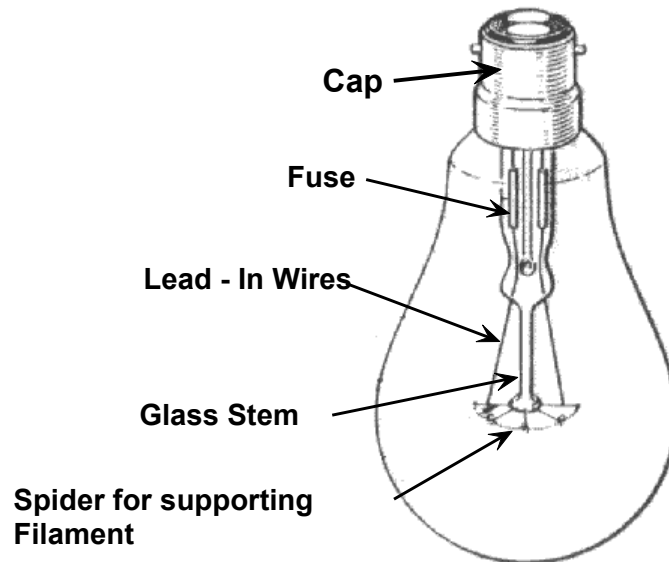

Figure 36.

There are two types of incandescent lamp:

- The Vacuum Lamp
- The Gas Filled Lamp

1. Vacuum Lamp

To prevent oxidation and premature failure of the lamp filament, all oxygen has to be removed from the glass bulb. The filament is operated in a vacuum. The vacuum has the disadvantage that the filament vaporises at a lower temperature. This allows tungsten to condense on the internal surface of the bulb. The result is, blackening of the bulb and a consequent reduction of efficiency. The highest temperature at which it is possible to operate the filament is approximately 2100°C.

2. Gas Filled Lamp

To overcome the disadvantages of the vacuum lamp, a mixture of Argon and Nitrogen Gas is introduced into the bulb. This raises the operating temperature to 2500°C approx. before blackening takes place. To reduce excessive heat loss due to convection the filament is coiled. A thin layer of gas attaches itself to the filament. The convection current of gas glides over this fixed layer. The result is that only the outside of the coil is cooled.

The light output covers the visible spectrum giving a warm white to yellow light with **good colour rendering**. This means that the colours of articles viewed in the light of a GLS lamp are faithfully reproduced. The life expectancy of a modern GLS lamp is about **1,000 hours**.

The GLS lamp is unchallenged as the domestic light source. Despite the availability of **more efficient lamps** there are more GLS lamps produced each year than any other type.

One factor which may have contributed to the popularity of the GLS lamp is that designers have been able to modify the glass envelope to give a very pleasing decorative appearance as shown in Figure 37.

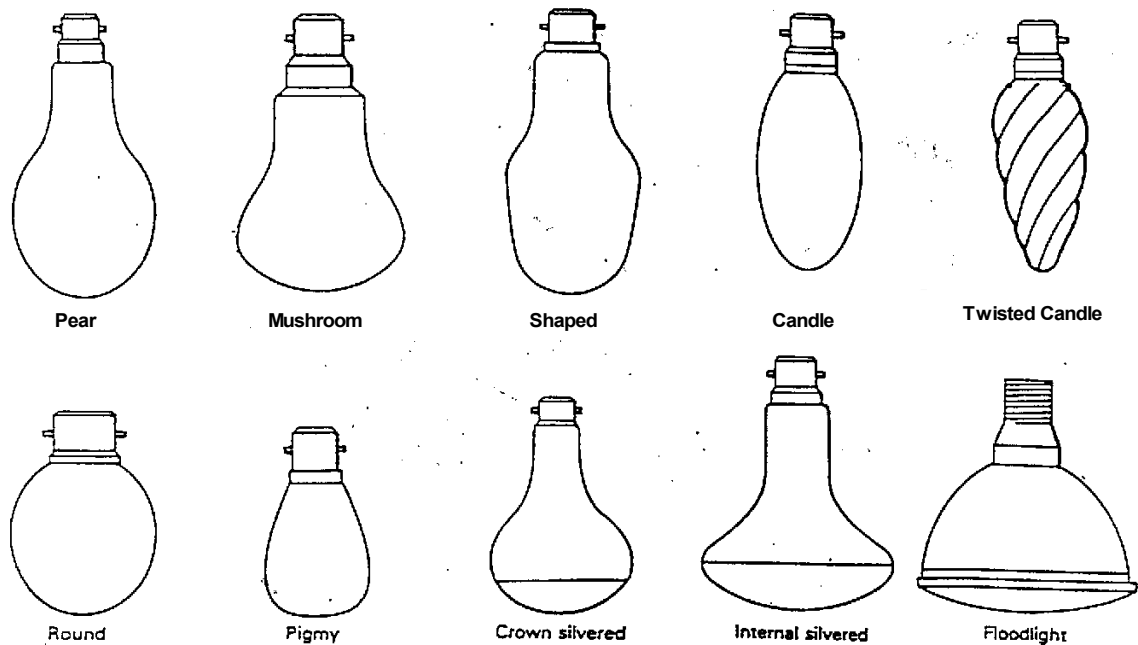

Figure 37.

There are many different lamp designs on the market today:

- double-life lamps with special coiled-coil filaments
- rough service lamps with special shock-resistant properties
- reflector lamps used for display lighting
- decorative lamps
- heating lamps and other lamps for special applications.

Filament lamps are best operated in their cap-up position.

For every 5% increase in steady operating voltage over the rated voltage, the life of the lamp is approximately halved.

Bulb Types

There are three main types of bulb:

Clear - a transparent bulb of clear glass, suitable for use in enclosed fittings where the bulb is not visible. This is to reduce glare.

Pearl - acid treated on the inside, which causes **diffusion** of the light and reduces glare, suitable for open-bottom type fittings.

Silica Coated - coated internally with a white silica compound and are usually mushroom shaped. They produce glare free light.

GLS lamps are also available in a variety of colours to provide festive lighting.

A much smaller version of the GLS known as a pygmy lamp is used in such places as fridges and ovens. These lamps are available in a range of colours and are often used to provide festive lighting. They may also be used where space is restricted or as indicator lamps.

Cap Types

Incandescent or tungsten filament lamps are classified according to the type of **cap**, by which they are connected to the supply. The two main types in use are the Bayonet Cap (**BC**) and the Edison Screw (**ES**)

Bayonet Cap (BC)

This is the most commonly used type where the filament ends terminate in raised solder contacts. These contacts connect to the corresponding pins in the lampholder and the lamp is held in position by the two retaining pins as shown in Figure 38.

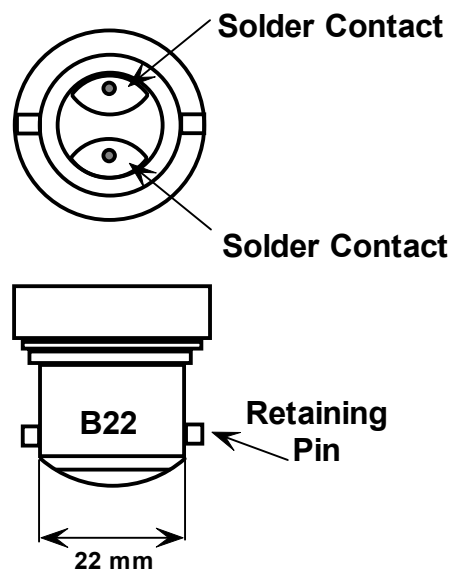

Figure 38.

Small Bayonet Cap (SBC)

Used in modern decorative light fittings. See Figure 39.

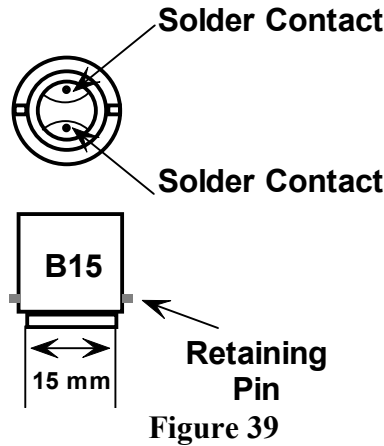

Figure 39

Small Centre Contact (SCC)

Often used as signalling lamps in industrial situations. See Figure 40.

Note: Phase must be connected to the centre contact.

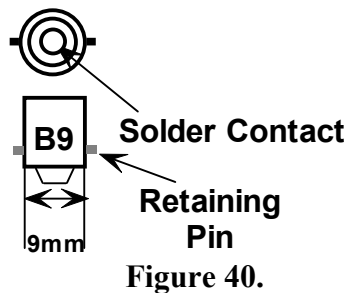

Figure 40.

Edison Screw (ES)

In this type of lamp the cap is threaded and screws into an Edison Screw lampholder. One side of the filament is connected to a centre contact while the other side is connected to the brass cap. The phase conductor is connected to a corresponding contact at the back of the lampholder while the neutral is connected to the threaded part.

These lamps are manufactured in the same range as BC types and are frequently used for spot lighting, infra red and reflector applications. See Figure 41.

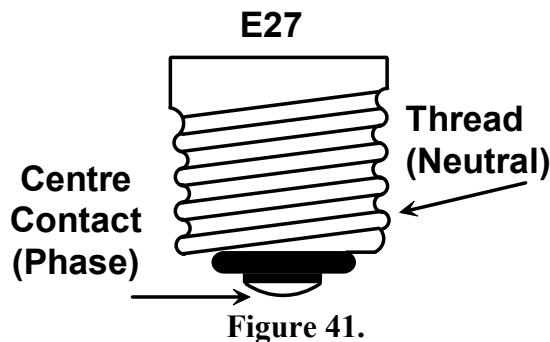

Figure 41.

Goliath Edison Screw (GES)

This is simply a larger version of the ES type (both physically and electrically). It is used for higher wattage lamps than the ES type, mainly for street lighting. See Figure 42.

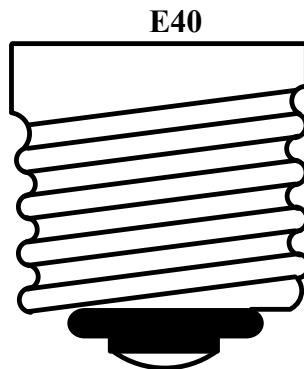

Figure 42.

Small Edison Screw (SES)

Used for lighting inside fridges / freezers and decorative lamps. See Figure 43.

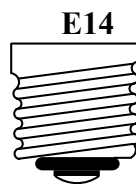

Figure 43.

Miniature Edison Screw (MES)

Used in older cookers and clothes irons as an indicator lamp, usually 2.5, 6, or 12 Volts. Also used in hand torches and bicycle lamps. See Figure 44.



Figure 44.

Safety

Always ensure that the ES lampholder is correctly connected, otherwise a person removing or replacing the lamp could receive a serious shock from the threaded part of the lamp or lampholder.

Lamp Ratings

Lamps are rated according to their wattage.

BC Lamps are available in the following wattages:

15, 25, 40, 60, 75, 100, 150, 200 Watts.

ES Lamps are available in the same general range as BC but up to 300 Watts.

GES Lamps are available up to 1500 Watts.

Lamp Life Span

The average life span of a tungsten filament lamp is **1000 hours**, provided that it is used correctly. There are three main problems associated with tungsten filament lamps:

1. Vibration
2. Heat
3. Ventilation

1. Vibration

When the filament, which is extremely fine, is at operating temperature any vibration or mechanical shock can cause distortion of the coil and rapid burnout.

NEVER check a lamp to see if it has blown by vibrating it.

2. Heat

In normal service, the lamp **dissipates heat**. It is important that high temperatures are avoided, in fittings wholly or partly made from plastics. The manufacturer's **maximum permitted lamp wattage** should **not** be exceeded. Most light fittings carry a label stating what this maximum wattage is. All too frequently users increase the wattage of the lamp, as the fittings will physically accept them. This practice should be avoided as it may be a **fire hazard** and also **shortens the life of the lamp**.

3. Ventilation

Enclosed fittings must have adequate ventilation otherwise the life of the lamp will be shortened.

Domestic Lighting Circuits

There are three basic methods of wiring lights in a domestic installation.

1. Loop-in method
2. Joint Box method
3. Three Plate Ceiling Rose method

Loop-in Method

The loop-in method is completed using 1.5mm² PVC / PVC single core cables plus a Protective Conductor (PE). Switch feeds and switch wires are wired with brown cable. Neutrals are wired with blue cable. A protective conductor must be provided at all lighting points and at all switch positions. These must be insulated with Green / Yellow sleeving. Switches are installed at a standard height of 1.1 metres above the finished floor level (FFL).

Lamps are placed in the centre of room ceilings except when more than one lamp is to be fitted. There should be no more than ten lighting points per circuit. There should be at least two lighting circuits per dwelling. This is to ensure that the entire house is not plunged into darkness if one lighting circuit fails. Figure 45 shows how three lamps, individually controlled by one-way switches are connected to the supply.

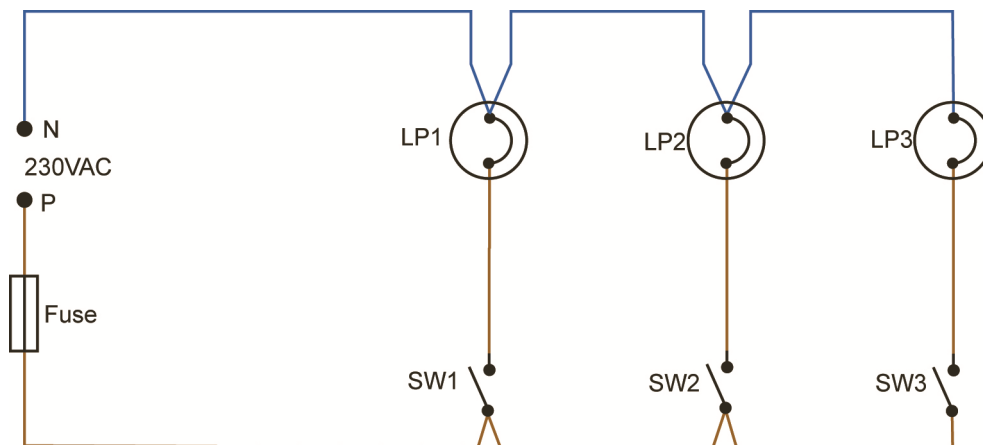

Figure 45.

Switch 1 will control lamp 1
 Switch 2 will control lamp 2
 Switch 3 will control lamp 3

All connections are made at the switches and light fittings and are therefore easily accessible. The lamps are connected in parallel but separately switched. When all switches are in the “**up**” position, all lamps will be “**off**”.

N.B. It is extremely important to note that a fuse or MCB and the control switch must interrupt the phase conductor of the supply.

Joint Box Method

The joint box method may be completed using 1.5mm² PVC / PVC single core cables plus a protective conductor, or 1.5mm² Twin and Earth PVC / PVC cable.

The phase and neutral conductors are looped into the joint boxes using brown and blue cores respectively.

Neutrals and switch wires are run between joint boxes and batten lampholders / ceiling roses.

Protective conductors are connected at all accessories.

Switch feeds and switch wires are run between joint boxes and switches. A twin brown cable is available for this purpose.

The running in of cables is completed simply and efficiently, but connecting up of accessories takes considerably longer than for the loop-in method.

Figure 46 shows how two lamps, individually controlled by one-way switches, are connected to the supply. Protective conductors are omitted for clarity.

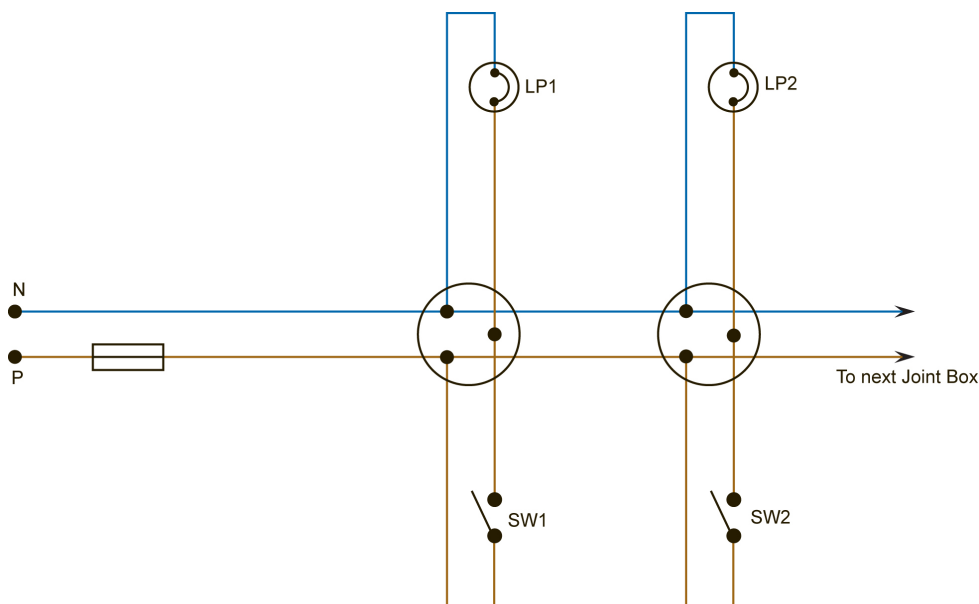

Figure 46.

IMPORTANT: All neutral conductors must have blue insulation.

All live conductors, switch feeds and switch wires must have brown insulation.

All protective conductors must have Green / Yellow insulation or sleeving.

This method of wiring lights is no longer used in domestic installations. It will of course be encountered in older installations for many years yet.

Note: Joint box must be fixed in position.

Three Plate Ceiling Rose Method

The three plate ceiling rose method may be completed in a similar manner to the joint box method. The three plate ceiling rose actually replaces the joint box and the batten lampholder or two plate ceiling rose. As a result there are fewer cables to be run. This involves less time at the first fixing stage.

There are more terminations to be made off and most of these are at the ceiling roses. This results in more time at the second fixing stage. All terminations will be accessible within the room.

Figure 47 shows how two lamps individually controlled by one-way switches are connected to the supply. Protective conductors are omitted for clarity.

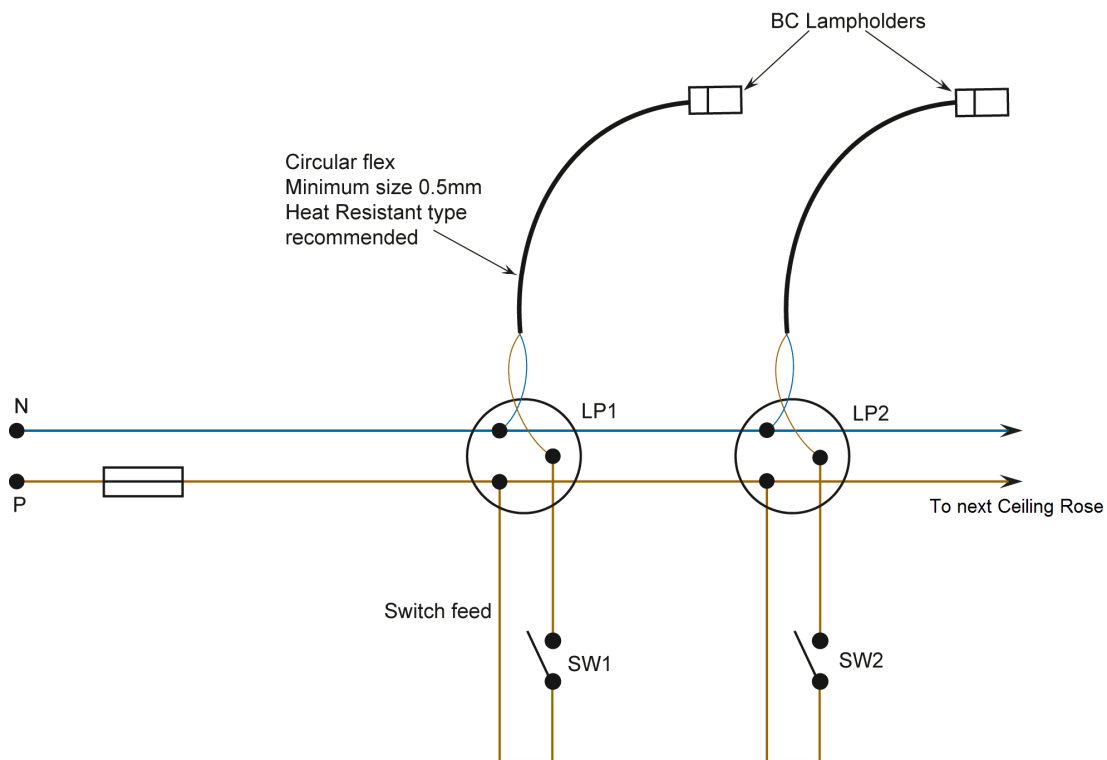

Figure 47.

All neutral conductors must have blue insulation.

All live conductors, switch feeds and switch wires must have brown insulation.

All protective conductors must have Green / Yellow sleeving.

Example of Lampholder Connections

Note use of cord grip

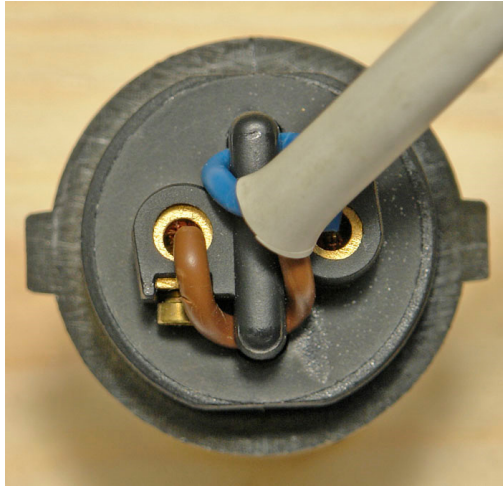

Figure 48.

Example of Ceiling Rose Connection

Note use of cord grip

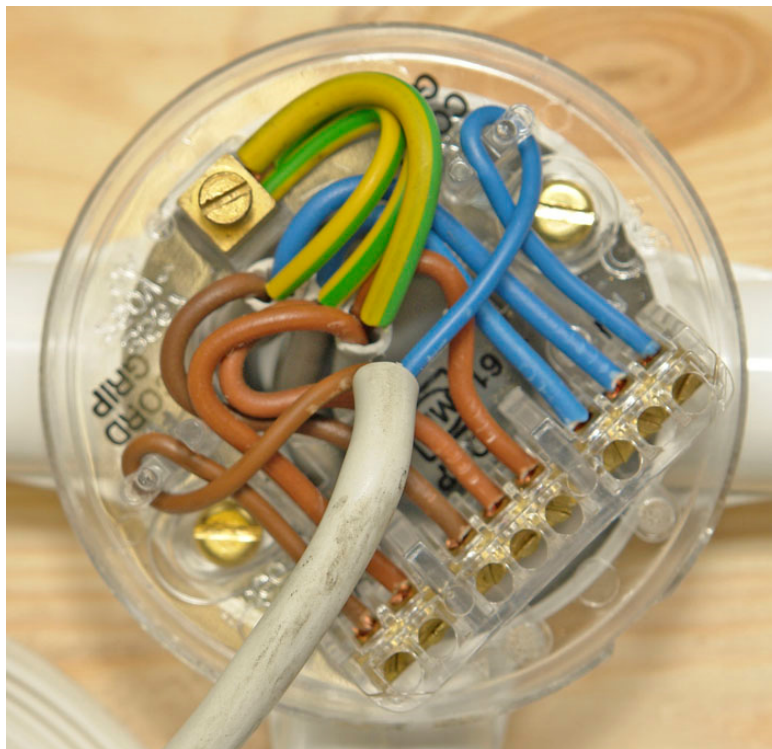

Figure 49.

Timeswitch Controlled Lighting

In any situation where lighting is required for certain hours of the day or week a basic timeswitch will provide this control. Timeswitches are available as 24 Hour or 7 Day models. Analogue and Digital versions are readily available.

An analogue timeswitch consists of a suitably rated electrical switch operated by a cam. The movement of this cam is provided by a train of gears driven by a small electric motor. The timing is accurate as the motor speed is governed by the frequency of the supply. The dial on a 24 Hour version rotates once every 24 Hours. The dial on a 7 Day version rotates once every 7 days.

A 24 Hour model will provide the same operation every day. A 7 Day model will provide the same operation every week, allowing for different switching times each day of the week. Some makes allow for only two “on” / “off” operations per day / week while others allow for much more. They are often used to provide outside lighting for houses, shops factories etc. Check manufacturers instructions on setting the timeswitch.

Timeswitch Controlled Lighting Circuit

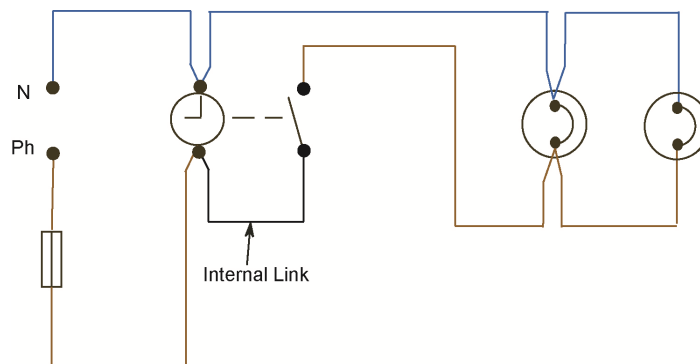

Figure 50.

Most timeswitches feature a built in switch. It may be labelled in different ways. It is however a simple two way switch with an “OFF” position. It allows for the timeswitch load to be *permanently off*, *permanently on* or *timed*. An indicator light is another useful feature as it gives clear indication that the supply is on the load. It is connected across the outgoing supply from the timeswitch.

N.B. Remember that any load supplied via a timeswitch may be powered up unexpectedly.

Typical Specifications

Voltage Rating	230 Volts AC 50Hz.	
Current Rating	16 Amps Resistive 4 Amps Inductive	
Switching Operations	24 Hour	48 on / off
	7 Day	96 on / off
Min. Switching Period	24 Hour	30 Minutes
	7 Day	105 Minutes

Analogue Timeswitch



Figure 51



Figure 52



Figure 53

Smoke Alarms

In the event of a fire, the presence of smoke in escape routes (stairways and hallways) is the greatest problem in effecting a safe exit from a building. Smoke alarm units should be installed in these areas. Almost half of domestic fires start in kitchens. Nearby exit routes must be protected. Electrical appliances and wiring cause 15% of fires. The most common cause of fatalities involves materials used by smokers. The use of electric blankets, particularly by the elderly is another high risk situation. People with impaired mobility require more time to escape. These areas must be protected.

Alarms will only work if sleeping occupants can hear them through a closed door. For people with a severe hearing impairment, a visual alarm and under pillow vibrating disc is recommended. These can be operated by a detector unit.

Smoke Alarm Systems are classified into six grades. The most elaborate system is a Grade A, while the most basic system is a grade F.

A Grade F System consists of one or more battery operated alarm units. These are the least reliable on account of the need for the battery to be checked periodically.

A Grade E System consists of one or more mains operated units. These are reliable only if there is a very low risk of loss of mains supply.

A Grade D System consists of one or more mains operated units with battery back up supply. These are the most reliable types as the battery maintains supply in the event of mains failure.

The system recommended in domestic premises is a Grade D.

There are three different types of detector.

1. Ionisation
2. Optical
3. Heat

An explanation of how they operate is beyond the scope of Phase 2.

The minimum requirement for most domestic installations is four detectors. One ionisation type fitted upstairs on the landing and one optical type fitted downstairs in the hallway.

The optical type should be used on the same floor as the kitchen. It is much less likely to be triggered by cooking operations than the ionisation type. A heat detector should be installed in the kitchen. A smoke or heat detector should be installed in the main living room. A more elaborate system may of course be installed.

Detectors should be installed in the centre of ceilings if possible. They should be at least 300 mm from any light fitting in the room. All units should be supplied directly from the same lighting circuit MCB. This is for safety reasons, as all units are interconnected. The interconnect wire should be treated as if it were a live conductor. Supplying the units from a lighting circuit automatically provides monitoring of the mains supply to them.

Units should be interconnected so that if one is triggered, all other units will alarm. Observe correct polarity of supply to all interconnected units. If polarity is wrong, damage **will** be done through the interconnection.

Units should **not** be attached to their mounting plates until all building work is completed. This is to avoid contamination by dust etc. Some manufacturers provide dust covers to overcome this problem.

N.B. Disconnect units during Insulation Resistance testing as the high test voltage will cause damage. This test is best done before the units are installed on their mounting bases.

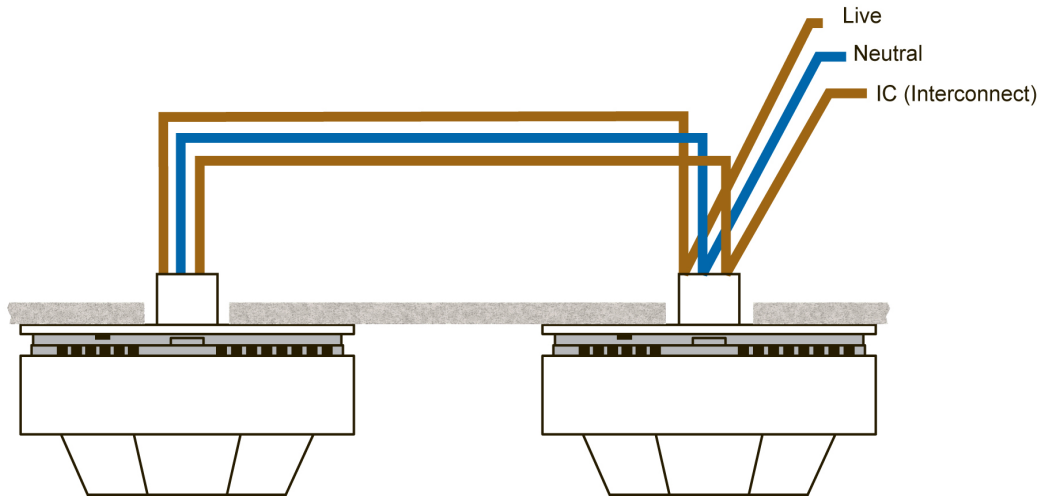

Figure 54



Figure 55

Testing Lighting Circuits

A “**polarity test**” must be done on all lighting circuits when new or after an alteration has been made. This is to ensure that the phase conductor is connected to the FUSE or MCB and single pole switches, rather than the neutral. See Figure 56. Any Edison Screw type lampholder should also be checked to ensure that the phase conductor is connected to the centre contact and the neutral to the screw contact,. See Figure 57.

This test must be done with the supply “DISCONNECTED” and may be carried out as follows:

- Remove circuit FUSE or open MCB.
- Remove all lamps from relevant circuit.
- Connect one lead of the ohmmeter to the phase conductor in the distribution board as shown.
A wander lead of known resistance is required to reach from the distribution board to each switch and lamp position.
- Connect the other lead to the switch feed terminal. See Figure 56.

A very low resistance value should be indicated, corresponding to the length and CSA of the conductor involved. This resistance should be indicated, regardless of the switch position, i.e. “on” or “off”.

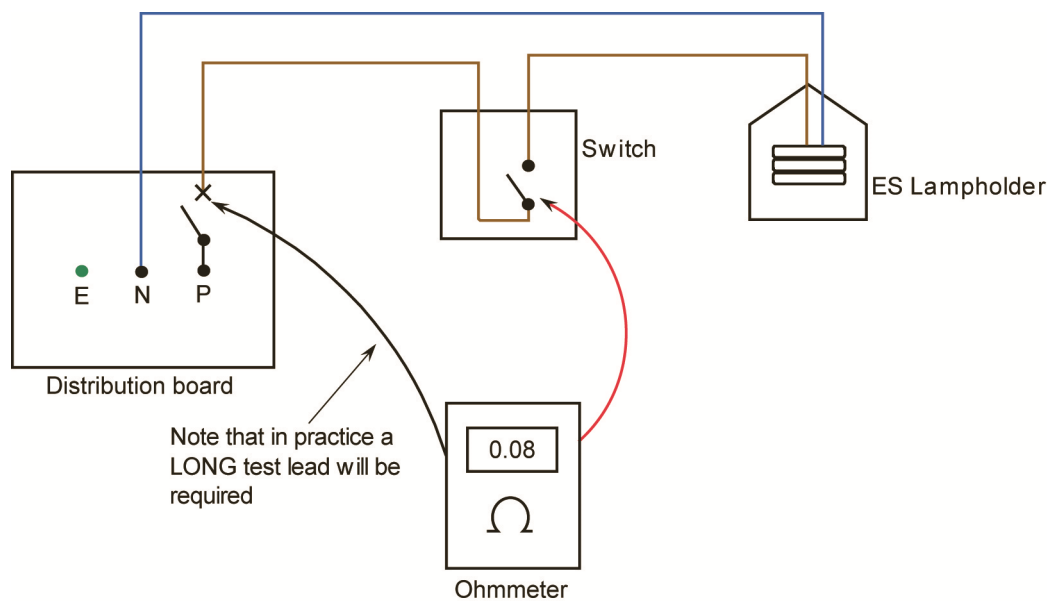

Figure 56.

- Move lead to the ES centre contact. See Figure 57.

A very low resistance value should be indicated, only when the switch is in the “on” position.

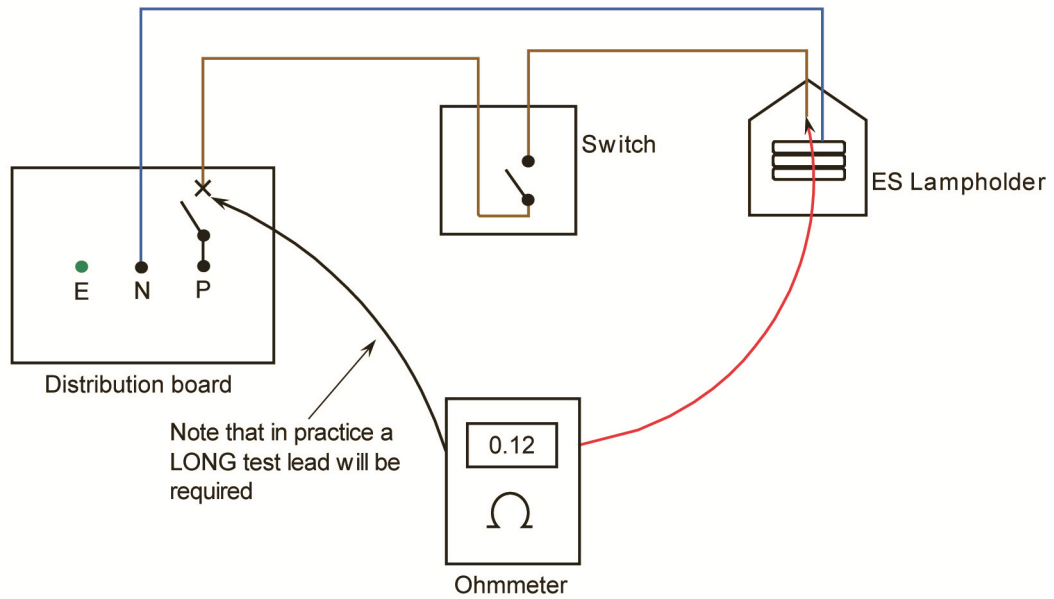

Figure 57.

Note:

The circuit switch must be operated when checking polarity of ES lampholder.

If the continuity of the neutral conductor is also checked, we can say that the circuit will function correctly.

Mini-trunking Systems

There is a wide variety of types and sizes of plastic mini-trunking manufactured today. One of the most common sizes of mini-trunking in use is 25mm wide and 16mm deep.

The following table illustrates the range of sizes available from one manufacturer. Sizes are quoted in millimetres.

Sizes:	1 compartment	2 compartment
	16 x 10	38 x 16
	16 x 16	38 x 25
	25 x 16	75 x 16
	38 x 16	
	38 x 25	
	50 x 25	
	38 x 38	

Plastic mini-trunking is also available in sizes from 10 x 8mm to 38 x 25mm in self-fixing format. It has double-sided adhesive tape for ease of installation. The lid can easily be removed for maintenance or alteration of the wiring system.

Figure 58 illustrates a section of 16 x 16mm mini-trunking, also shown is how the lid is fixed in place.

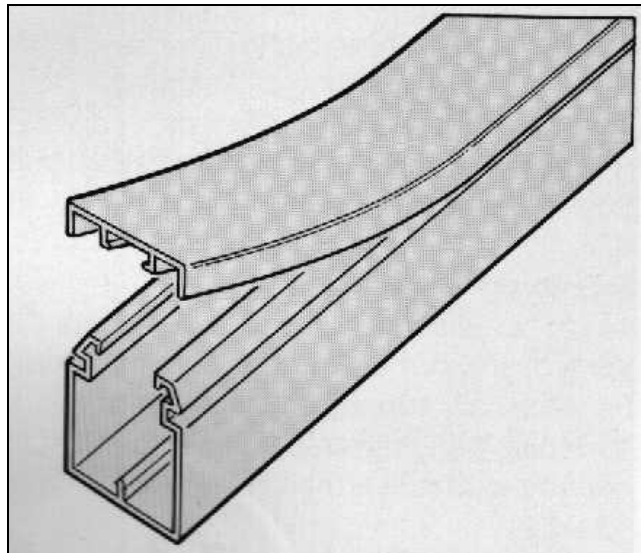

Figure 58.

There is a wide range of snap-on mini-trunking fittings available. These allow for changes in trunking sizes and the direction of trunking runs.

Figure 59 illustrates a sample of the snap-on fittings available:-

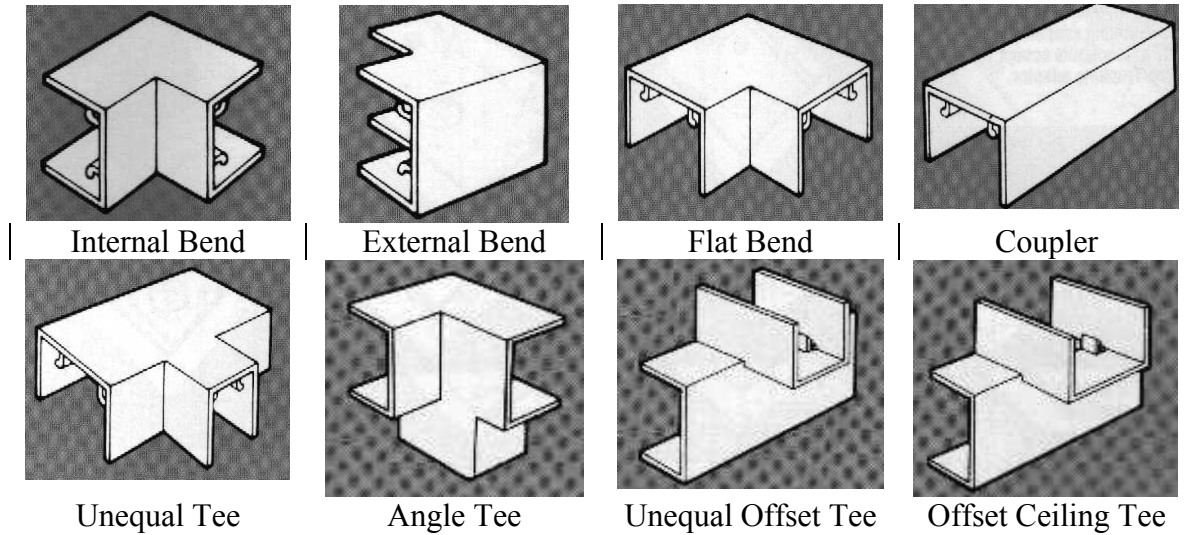

Figure 59.

Also available is a range of switch and socket boxes to suit the various trunking sizes.

Figure 60 shows a single switch box, which is 19mm deep and has knockouts to cater for 16 x 16mm or 25 x 16mm trunking entering the top or bottom. The box may be fitted either way up to allow either size of trunking enter in the centre or towards the left or right hand corners. Note the slotted fixing holes, which facilitate accurate alignment.

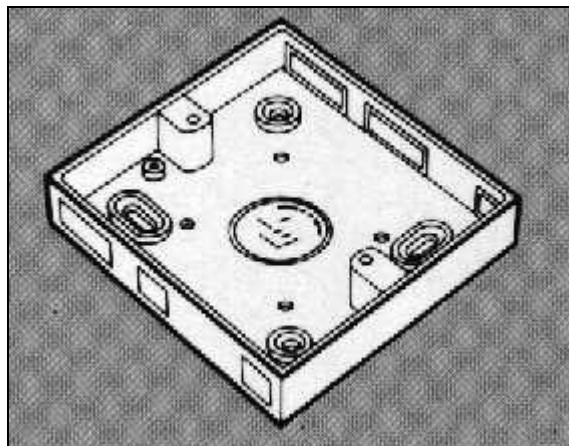

Figure 60.

Figure 61 shows a single socket box, which is 25mm deep. Other box sizes are available to accept larger accessories or cables.

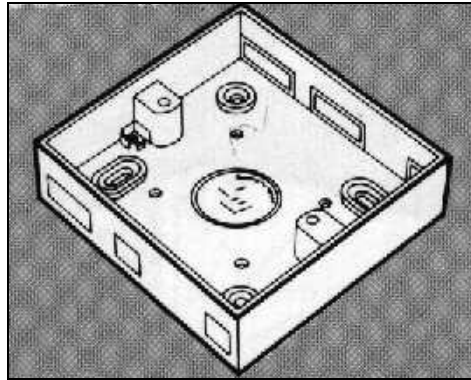
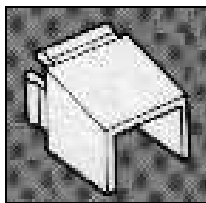
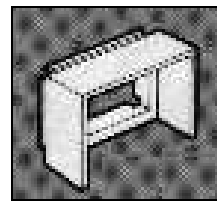

Figure 61.

Figure 62 illustrates the adaptors used to terminate the plastic trunking into the type of box shown in Figures 60 and 61. This adaptor simply clicks into position on the box.



16 x 16



25 x 16

Figure 62.

Figure 63 shows a double socket box, which is 32mm deep. This particular box allows for the direct entry of 25 x 16mm trunking to the centre, top or bottom. Side entry versions of all these boxes are also available.

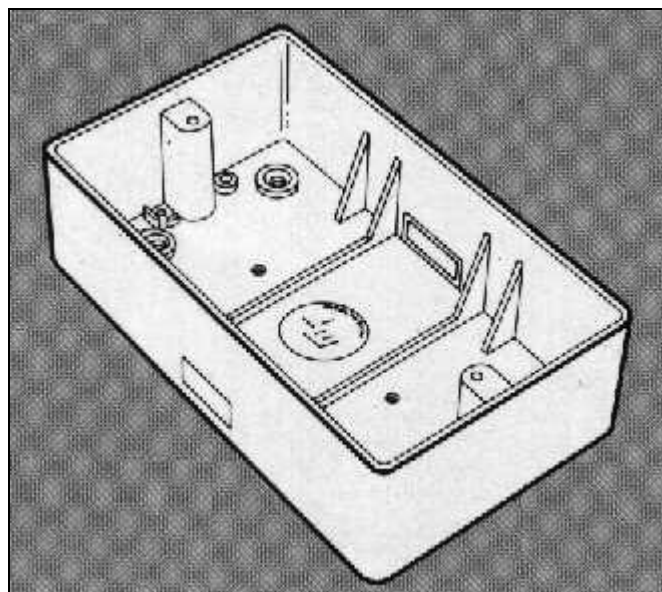

Figure 63.

Figure 64 shows a ceiling rose adaptor. The adaptor allows for the entry of 16 x 16mm or 25 x 16mm trunking. It is designed to accept all popular makes of ceiling rose and batten lampholder.

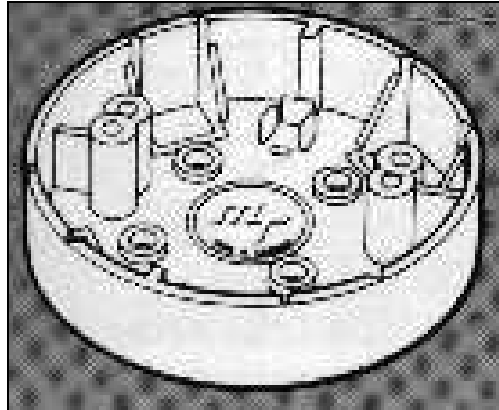

Figure 64.

Fixing Switch and Socket Boxes

- Select appropriate box and mark position.
- Select required knockout in box (LH., RH, centre, top or bottom), remove the knockout and then remove burrs from aperture.
- Snap in appropriate adaptor. This can more easily be done, by using a short length of trunking inserted in adaptor.
- Punch through the fixing holes in back of box and secure with screws.
- Insert the trunking into the box making sure that it seats securely in the adaptor.

Self-Fixing Mini-Trunking

To locate self-fixing mini-trunking, peel off the backing paper exposing 500mm of self adhesive tape at a time. Line up the trunking accurately and press home. The self-adhesive tape will bond to almost any dust-free surface. Surfaces must be smooth and flat. Uneven surface contact will reduce the bonding performance of the self-adhesive tape. Surfaces must be clean and dry. Installation of trunking in cold conditions may affect adhesion. Wood, plaster, plastics, metals, brick, paintwork, paper and glass are suitable surfaces.

Fixing Mini-Trunking

The fixing technique used will vary depending on whether the joints are **mitred** or **moulded fittings** are used.

Mitred Joints:

1. Plan the route of the main trunking run together with tees, drops to switches and socket outlets etc. Mark the positions and fix all boxes.
2. The trunking must be **accurately mitred** for bends and tees etc. Cut the trunking body and lid in the one operation. Where frequent temperature changes are likely, allow for expansion of approximately **0.7mm per 10°C per metre**. Fix the body of the trunking by drilling **oversized holes** and screwing through the base with **roundhead screws**. Do not over tighten the fixing screws. The oversized holes allow for **movement due to expansion**. It is recommended that for installations at **low level**, fixing centres should be no greater than **375mm**. For **high level** installations fixing centres should be no greater than **600mm**.
3. Cables are now installed. Clip on the lid, making sure that the **lid** and **base** joints are **staggered** for better security. Ensure that the lid is clipped on properly throughout its length.

Moulded Fittings:

1. Plan the route of the main trunking run together with tees, drops to switches and socket outlets etc. Mark the positions and fix all boxes.
2. Where moulded fittings are used the need for accurate mitring is eliminated. The trunking ends need only be cut to butt each other. Where frequent temperature changes are likely, allow for expansion of approximately **0.7mm per 10°C per metre**. Fix the body of the trunking by drilling **oversized holes** and screwing through the base with **roundhead screws**. Do not over tighten the fixing screws. The oversized holes allow for **movement due to expansion**. It is recommended that for installations at **low level**, fixing centres should be no greater than **375mm**. For **high level** installations fixing centres should be no greater than **600mm**.
3. Cables are now installed. Clip on the lid by sliding one end under the cover of the first moulded fitting. Mark the lid about **6mm** beyond the next fitting and cut. Spring the end of the lid under next fitting and snap it into position along the main body of the trunking. Repeat this procedure between fittings until installation is complete.

Mini-Trunking Fitting

Coupler

Cut the trunking to length as required. Allowing an appropriate gap for expansion, butt the ends together, as shown in Figure 65.

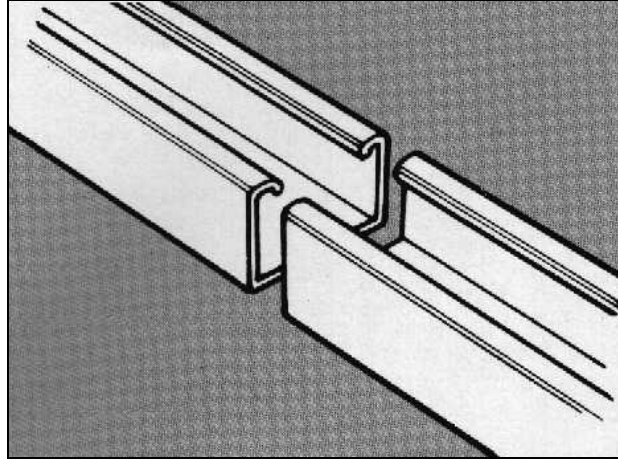

Figure 65

Tee

Cut the trunking to length as required. Remove a section of the sidewall of the through trunking. Allowing an appropriate gap for expansion, butt the tee trunking to the opening, as shown in Figure 66.

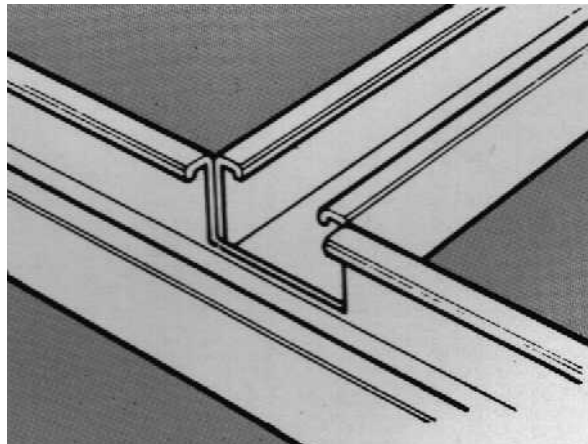

Figure 66.

Flat Bend

Cut the trunking to length as required. Remove a section of sidewall. Allowing an appropriate gap for expansion, butt the ends together, as shown in Figure 67. This method is only suitable where a moulded fitting is to be used.

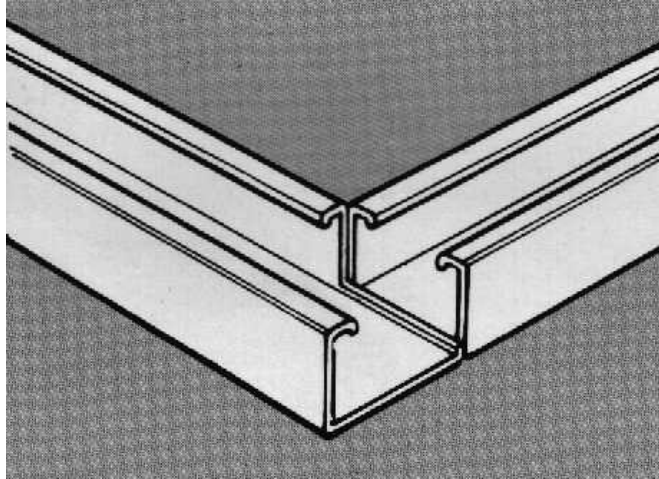

Figure 67.

Alternatively the ends of the trunking may be mitred as shown in Figure 68.

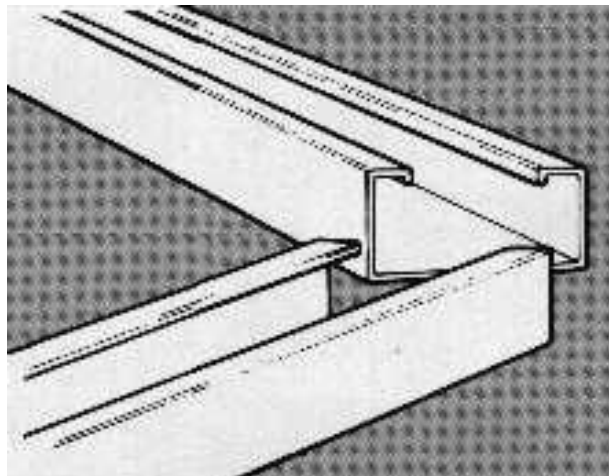

Figure 68.

Internal Bend

Cut the trunking to length as required. Remove a section of sidewall on one piece. Leave the back of the trunking intact to complete the enclosure. Allowing an appropriate gap for expansion, butt the ends together. See Figure 69.

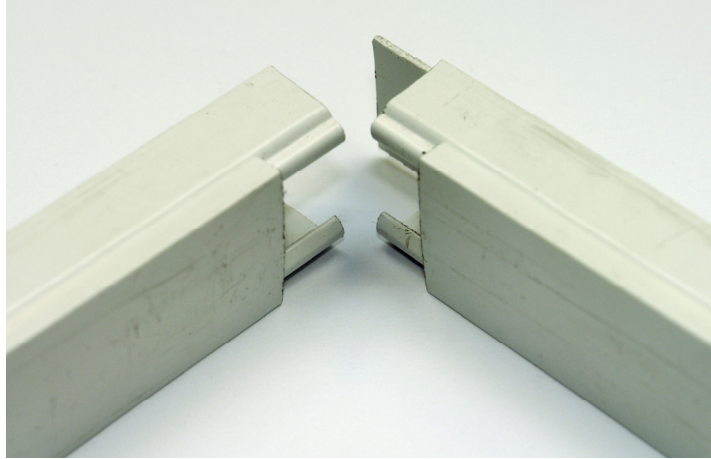

Figure 69.

Alternatively the ends of the trunking may be mitred as shown in Figure 70.

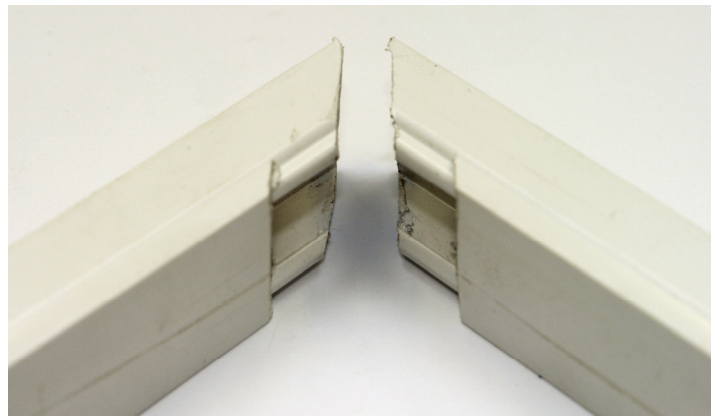

Figure 70

Ceiling Tee

Cut the trunking to length as required. Remove a section of the lip of the through trunking. Allowing an appropriate gap for expansion, butt the tee trunking to the opening, as shown in Figure 71.

Alternatively, an offset tee may be used if the through trunking is run below ceiling height.

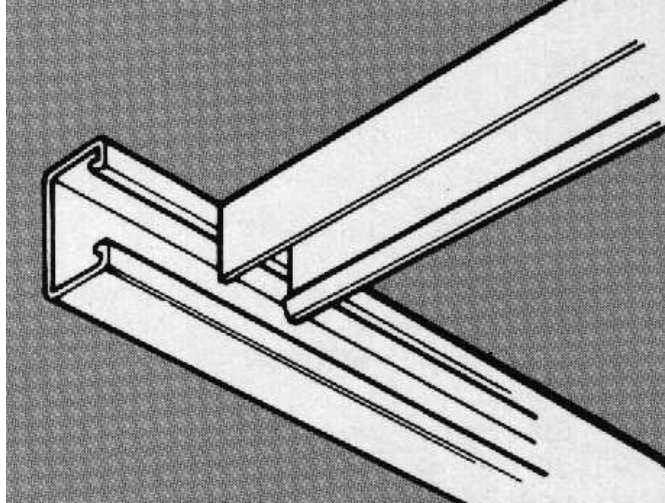

Figure 71.

Ceiling Rose Adaptor

Break out the appropriate knockout(s) in ceiling rose adaptor. Fix ceiling rose adaptor in position. Cut the trunking to length as required and fix to ceiling.

A dummy run of trunking may be fixed to the opposite side of the ceiling rose adaptor in order to achieve a visual balance. Running on through the ceiling rose adaptor will facilitate a second light fitting, see Figure 72.

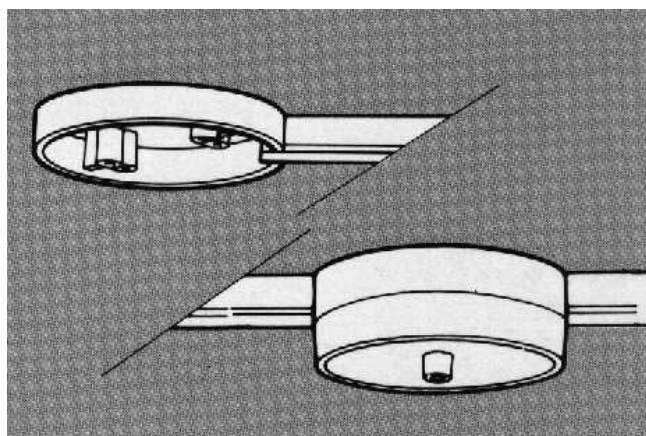

Figure 72.

Dry Lining Boxes

Figure 73 shows a single gang dry lining box. It is manufactured in three sizes to suit any board thickness from 10mm to 25mm. This box will accommodate plate switches, single sockets etc.



Figure 73.

Figure 74 shows a twin dry lining box. It is also available in the three sizes mentioned above. This box will accommodate double plate switches and twin sockets. A deeper version is available for cooker switches and shaver sockets.

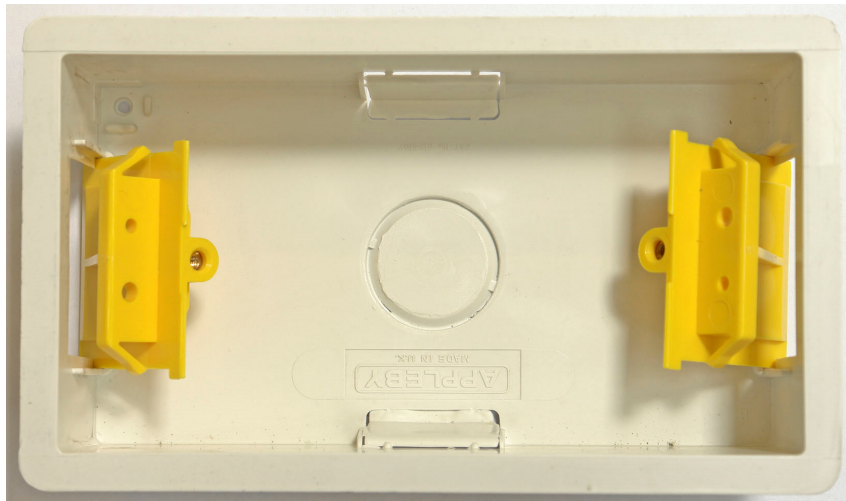

Figure 74.

Figure 75 shows a dual dry lining box. It will allow any two single accessories to be fitted side by side. The box segregates the wiring to these accessories which is a requirement by the ETCI Rules in certain circumstances.

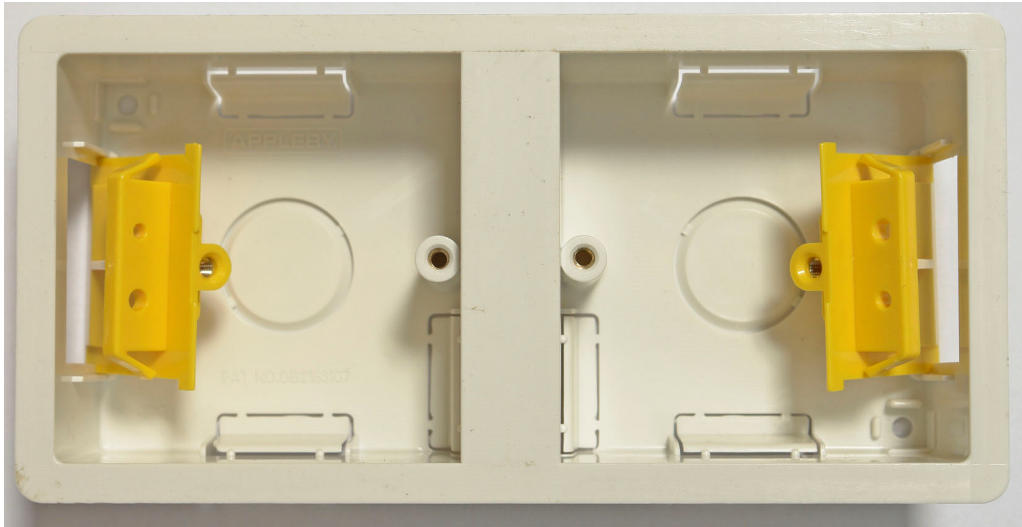

Figure 75

A circular dry lining box is also available which may be used to fix ceiling roses, batten lampholders, pull cord switches etc. It can be fixed to any board having a thickness between 10mm and 32mm. See Figure 76.



Figure 76

All dry lining boxes feature securing lugs which are used to retain the box in position.
See Figure 77.

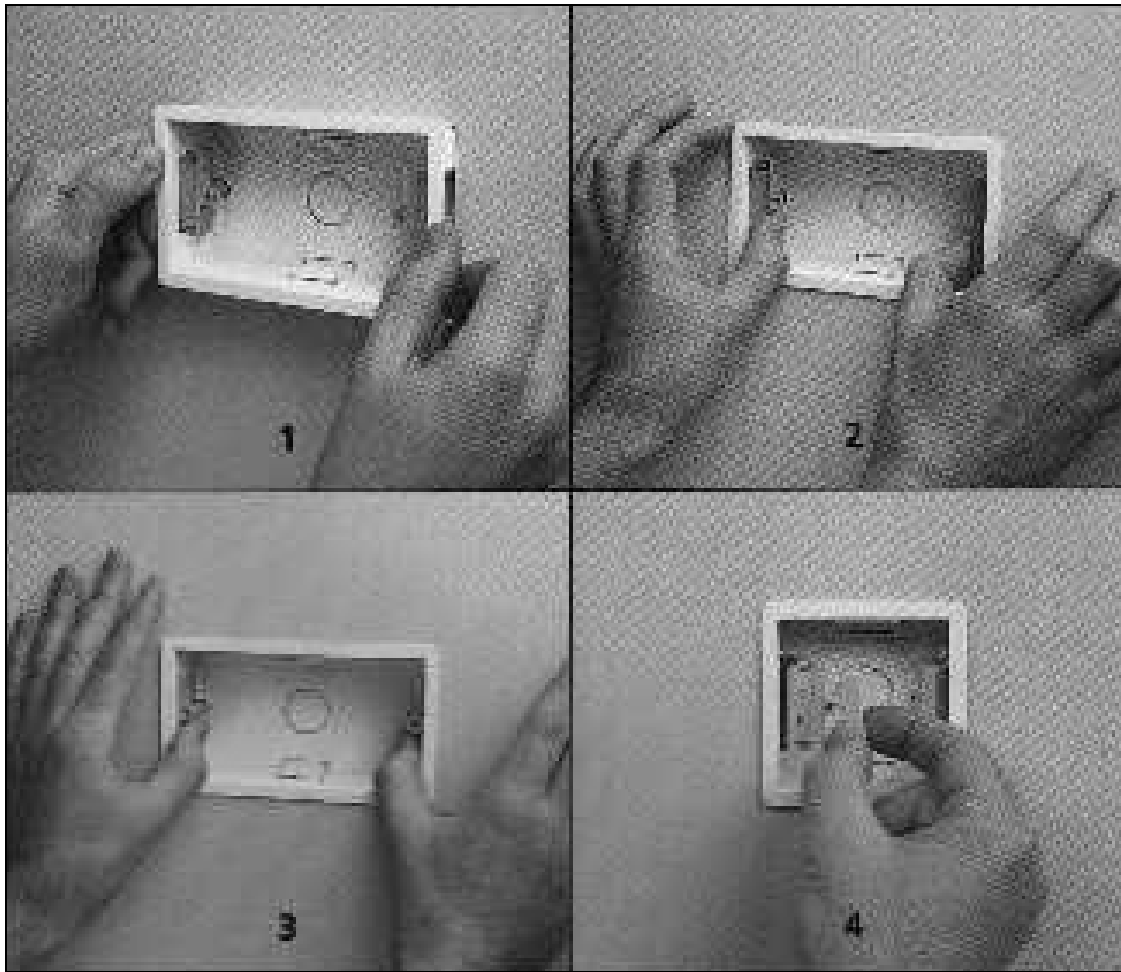

Figure 77.

Fitting Dry Lining Boxes

When fitting dry lining boxes, the back of the box should be used to mark out the shape of the hole to be cut in the plasterboard. To commence cutting out this hole, pierce through the plasterboard in the centre of the marked area, using a bradawl. In the case of wooden partitions a drill bit should be used. A pad saw can then be inserted through this hole and used to neatly cut out the shape required. Alternatively a jigsaw may be used.

The box should be a snug fit in the hole. Particular care should be taken when cutting out holes for circular boxes. Circular boxes have either ribbed or shaped sections to prevent rotation in the hole.

Dry lining boxes have a large flange at the front, which prevents them passing through the hole into the cavity. This flange matches the profile of the accessory front plate.

To install an accessory using a dry lining box, proceed as follows:

- Cut a suitable hole in the plasterboard as described above.
- Install the required cables through this hole.
- Remove the required knockouts from the box.
- Pass the cables through these entries.
- Work the box into the hole in the plasterboard.
- Position the securing lugs behind the plasterboard.
- Connect the cables to the accessory.
- Position the accessory against the box flange, being careful not to damage the cables.
- Pass fixing screws through accessory and screw into the brass inserts in the securing lugs.
- Tighten the screws until the accessory is secure.

Tightening of the fixing screws pulls the securing lugs of the box against the inner surface of the dry lining board.

Unit Related ETCI Rules

Isolation	462 462.1 462.2 462.3 462.4
Distribution Boards	530 530.5, 530.5.1, 530.5.2, 530.5.3, 530.5.4, 530.5.6, 530.5.7, 530.5.8, 530.5.10, 530.5.11, 530.5.12
Switches	530.6
Luminaires	559 559.1 559.3 559.4, 559.4.1, 559.4.2 559.5, 559.5.1, 559.5.2 559.6, 559.6.1 559.6.2, 559.6.3, 559.6.3.1, 559.6.3.2 559.6, 559.6.4, 559.6.5 559.11
Final Circuit Arrangements	Annex 55A 1 (Lighting Circuits only) 4, 4.1