

Trade of Motor Mechanic

Module 8

Unit 1

BRAKING SYSTEM MECHANICALS

Produced by

SOLAS

An tSeirbhís Oideachais Leanúnaigh agus Scileanna
Further Education and Training Authority

In cooperation with:

Subject Matter Experts

Martin McMahon

&

CDX Global

Curriculum Revision 2.2 16-01-07

© SOLAS 2013

Table of Contents

| | |
|--|----|
| Introduction..... | 1 |
| Unit Objective..... | 2 |
| 1.0 Health, Safety and Precautionary Procedures..... | 3 |
| 1.1 Health and Safety..... | 3 |
| 2.0 Personal Hazards and Environmental Issues | 4 |
| 2.1 Personal/Environmental Hazards | 4 |
| 2.2 Environmental Issues | 4 |
| 3.0 Functions of Automobile Braking Systems | 5 |
| 3.1 Principles of Braking..... | 5 |
| 4.0 Principles of Friction Related to the Brakes | 7 |
| 4.1 Friction..... | 7 |
| 4.2 Measuring the Coefficient Of Friction..... | 9 |
| 4.3 Effects of Temperature on Friction..... | 10 |
| 5.0 Factors Affecting Braking/Stopping Distances..... | 11 |
| 5.1 Factors Affecting Braking/Stopping Distances | 11 |
| 6.0 Principles of Operation of the Drum Brake System | 12 |
| 6.1 Drum Brake | 12 |
| 6.2 Drum Brake Operation | 12 |
| 6.3 Drum Brake Components..... | 15 |
| 6.4 Backing Plate | 17 |
| 6.5 Wheel Cylinders | 18 |
| 6.6 Brake Linings & Shoes | 18 |
| 7.0 Brake Shoe Arrangements | 20 |
| 8.0 The Term 'Self-Servo Action' as Applied to Drum Brakes | 20 |
| 8.1 Self Servo Action..... | 20 |
| 9.0 Servicing Drum Brake Assembly..... | 21 |
| 10.0 Principles of Operation of the Disc Brake System..... | 22 |
| 10.1 Disk Brake Operation | 22 |
| 10.2 Disk Brake Rotors (Brake Disk)..... | 26 |
| 10.3 Disk Brake Pads..... | 27 |
| 10.4 Disk Brake Callipers | 28 |
| 11.0 The Term 'Brake Fade' | 29 |
| 11.1 Brake Fade | 29 |
| 12.0 Servicing Disc Brake Assembly..... | 30 |
| 13.0 Comparing Disc and Drum Brake Systems | 31 |
| 13.1 Advantages and Disadvantages of Disk/Drum Brakes..... | 31 |
| 14.0 The Use of Brake Pedal as a Lever | 32 |
| 14.1 Brake Pedal | 32 |
| 14.2 Brake Pedal Leverage | 33 |
| 15.0 Mechanical Handbrake used with a Drum Brake System..... | 35 |
| 15.1 Parking Brakes..... | 35 |
| 16.0 Adjust the Handbrake Mechanism | 36 |
| 17.0 NCT/DoT VTM Requirements | 36 |
| 17.1 NCT Requirements | 36 |
| 18.0 NCT/DoT VTM Requirements | 36 |
| Self Assessment..... | 37 |
| Suggested Exercises | 39 |
| Training Resources..... | 39 |
| Suggested Further Reading | 40 |

Introduction

Module 8 of this course covers the Braking System aspect of automotive technology. This is the first unit in module 8 and introduces the fundamental principles associated with the Mechanical part of the Braking System.

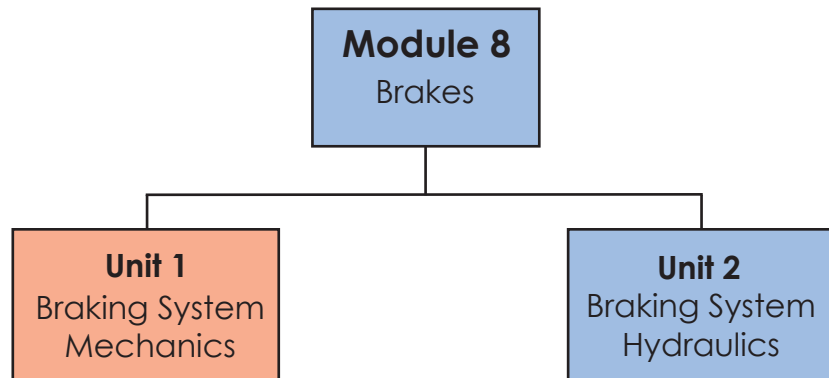

The Purpose of the automobile braking system is to reduce the speed of the automobile. This is achieved by the brake system converting kinetic energy to heat energy. Several factors can influence vehicle braking: driver reaction, Road surface, Road conditions, Weight of the vehicle, Load on the wheel during stopping, Different manoeuvres and the tyres on the vehicle. An effective braking system takes all these factors into account. This unit will cover the key mechanical components associated with the brake system and the relevant environment, health and safety.

Unit Objective

By the end of this unit each apprentice will be able to:

- State and apply the health, safety and precautionary procedures applicable to working on the braking system mechanicals
- Describe the personal hazards and environmental issues associated with brake lining dust and brake fluid
- State the purpose of the automobile braking system and the essential functions it must perform
- Explain the principles of friction related to the brakes
- List the factors affecting braking/stopping distances
- Describe the principles of operation of the drum brake system
- Distinguish between brake shoe arrangements
- Define the term 'self-servo action' as applied to drum brakes
- Dismantle a drum brake assembly, examine components and compare their condition to recommended specifications, refit/replace components as necessary, adjust and reassemble
- Describe the principles of operation of the disc brake system
- Define the term 'brake fade'
- Dismantle a disc brake assembly, examine components and compare their condition to recommended specifications, refit/replace components as necessary and reassemble
- Compare the disc and drum brake systems
- Explain how the brake pedal acts as a lever
- State the function and describe the principles of operation of the mechanical handbrake used with a drum brake system
- Adjust the handbrake mechanism
- Outline the NCT/DoT VTM requirements applicable to the mechanical braking system
- Examine the operation and condition of the mechanical braking system of automotive vehicles for compliance with NCT/DoT VTM requirements

1.0 Health, Safety and Precautionary Procedures

Key Learning Points

- Health and safety and precautionary procedures applicable to working on the braking system mechanicals (including safe use of trolley jack and axle stands/vehicle lifts, use of eye protection and latex gloves, removal of brake dust with appropriate brake cleaning fluid, use of suitable face mask to avoid respiratory problems, working with appropriate brake tools, prevention of brake fluid spillage, pumping and checking brake pedal pressure prior to road test etc.)

1.1 Health and Safety

If the proper safety procedures are not adhered when working on Braking Systems this could lead to serious injury/health problems to personnel.

Instruction is given in the proper safety precautions applicable to working on, Braking Systems include the following:

- Use of trolley jacks
- Axle stands
- Vehicle lifts
- Removal of brake dust with appropriate brake cleaning fluid and the Use of suitable face mask to avoid respiratory problems
- Use of appropriate brake tools
- Prevention of brake fluid spillage (Used brake fluid disposed off in accordance with environmental regulations)
- Danger of serious auto – accidents if final checks are not made prior to road test e.g. pumping & checking brake pedal pressure, brake fluid levels etc.
- Use of Personal Protective Equipment (PPE)

Refer to motor risk assessments, Environmental policy and Material Safety Data Sheets (MSDS).

2.0 Personal Hazards and Environmental Issues

Key Learning Points

- Personal hazards associated with brake lining dust and brake fluid
- Environmental issues associated with disposal of used brake fluid

2.1 Personal/Environmental Hazards

If the proper safety procedures are not adhered to in regard to linings dust and brake/clutch fluid when working on the Clutch /Braking Systems this could lead to serious health problems e.g.

- Respiratory problems from airborne dust
- Asbestos dust causes lung cancer (may not show for decades after exposure)
- Eye damage from fluid splashes

Instruction is given in the proper safety procedures applicable to working on Clutch/braking systems which include the following key point:

Use of appropriate PPE

Refer to motor risk assessments, Environmental policy and Material Safety Data Sheets (MSDS)

2.2 Environmental Issues

The Storage and disposal of brake lining dust and brake fluid must comply with current laws and regulations.

3.0 Functions of Automobile Braking Systems

Key Learning Points

- Purpose of the automobile braking system (converting kinetic energy to heat energy etc.)
- Essential functions performed by the braking system (including decelerating and bringing a vehicle to a standstill efficiently, application of equal braking force to both sides to ensure vehicle stability, efficient dissipation of heat energy etc.)

3.1 Principles of Braking

The Purpose of the automobile braking system is to reduce the speed of the automobile. This is achieved by the brake system converting kinetic energy to heat energy.

Several factors can influence vehicle braking:

- Road surface
- Driver reaction
- Road conditions
- Weight of the vehicle
- Load on the wheel during stopping
- Different manoeuvres
- The tyres on the vehicle.

An effective braking system takes all these factors into account.



A basic hydraulic braking system has 2 main sections:

- The brake assemblies at the wheels
- The hydraulic system that applies them

There is a brake for:

- When the vehicle is in motion (usually a foot brake) for retarding the vehicle motion or stopping the vehicle.
- A park brake for when it's stationary (usually operated by hand but in some incidences are foot actuated that is apply/release) to provide a parking phase.

Some systems have all drum brakes (usually old cars). Some have disc brakes on the front wheels and drum brakes on the rear others have all disc brakes.

A basic braking system has a:

- Brake pedal
- Master cylinder to provide hydraulic pressure
- Brake lines and hoses to connect the master cylinder to the brake assemblies
- Fluid to transmit force from the master cylinder to the wheel cylinders of the brake assemblies
- Brake assemblies (drum or disc) that stop the wheels.

The driver pushes the brake pedal; it applies force (mechanical) to the piston in the master cylinder. The piston applies pressure (hydraulic) to the fluid in the cylinder the lines transfer pressure (unlimited in all directions within the confines of the brake lines) to the wheel cylinders and the wheel cylinders at the wheel assemblies apply the brakes.

Equal breaking force is applied to both sides of the vehicle to ensure vehicle stability.

Force is transmitted through the fluid. For cylinders the same size the force transmitted from one is the same value as the force applied to the other. By using cylinders of different sizes forces can be increased or reduced.

In an actual braking system the master cylinder is smaller than the wheel cylinders so the force at all of the wheel cylinders is increased. When brakes are applied to a moving vehicle they absorb the vehicle's kinetic energy. Friction between the braking surfaces converts this energy into heat.

4.0 Principles of Friction Related to the Brakes

Key Learning Points

Principles of friction related to the brakes (including definition of friction static and sliding friction, conditions affecting friction, coefficient of friction, effect of temperature on friction etc.)

4.1 Friction

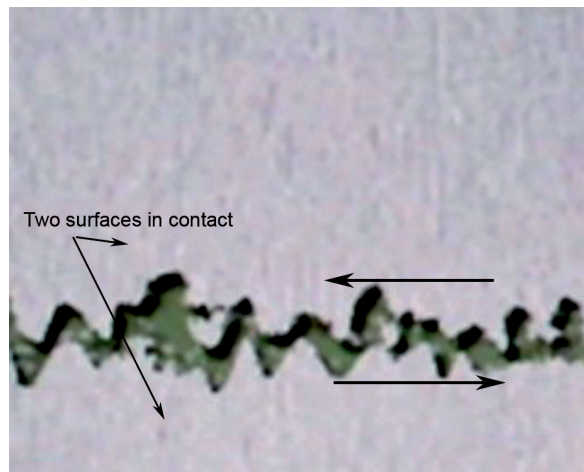

Friction is a force that resists the movement of one surface over another. In some instances it can be desirable; but more often is not desirable. It is caused by surface rough spots that lock together. These spots can be microscopically small which is why even surfaces that seem to be smooth can experience friction. Friction can be reduced but never eliminated.

- Friction is always measured for pairs of surfaces using what is called a coefficient of friction.
- *Low coefficient of friction* for a pair of surfaces means they can move easily over each other.
- *High coefficient of friction* for a pair of surfaces means they cannot move easily over each other.

Coefficient of Friction

The coefficient of friction (also known as the frictional coefficient or the friction coefficient) is a scalar value used to calculate the force of friction between two bodies. The coefficient of friction depends on the materials used -- for example ice on metal has a very low coefficient of friction (they rub together very easily) while rubber on pavement has a very high coefficient of friction (they do not rub together easily). It is interesting to note that contrary to common belief the force of friction is invariant to the size of the contact area between the two objects. This means that friction does not depend on the size of the objects.

The force of friction is always exerted in a direction that opposes movement. For example a chair sliding to the right across a floor experiences the force of friction in the left direction.

Types of Friction

Static Friction

Static friction occurs when the two objects are not moving relative to each other (like a desk on the ground). The coefficient of static friction is typically denoted as μ . The initial force to get an object moving is often dominated by static friction.

Kinetic Friction

Kinetic friction occurs when the two objects are moving relative to each other and rub together (like a sled on the ground). The coefficient of kinetic friction is typically denoted as μ (pronounced mew) and is usually less than the coefficient of static friction.

Sliding Friction

Sliding friction occurs when two objects are rubbing against each other. Putting a book flat on a desk and moving it around is an example of sliding friction.

4.2 Measuring the Coefficient Of Friction

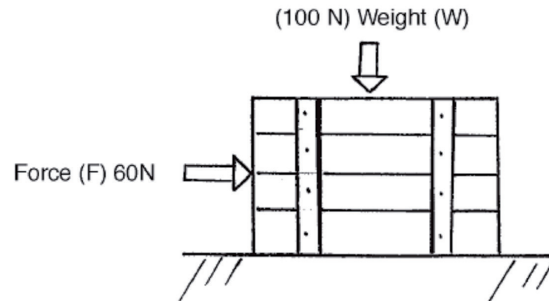

Measuring the Coefficient of Friction

$$\text{Coefficient of Friction} = \frac{\text{Sliding frictional force}}{\text{Force between surfaces}}$$

The symbol μ is a Greek word “pronounced mew” and is used for Coefficient of Friction.

$$\mu = \frac{F}{W}$$

$$\mu = \frac{60}{100} = .6$$

The friction that exists between the box and the floor we know is 0.6

| <i>Surfaces</i> | μ |
|-------------------------------------|-------|
| Tyre on normal road surfaces | 0.6 |
| Brake lining on cast iron drum | 0.4 |
| Clutch lining on cast iron flywheel | 0.35 |
| Metal to metal (dry) | 0.2 |
| Metal to metal (lubricated) | 0.1 |

4.3 Effects of Temperature on Friction

Most modern brake and clutch materials for the composition of shoes, pads and clutch facings, maintain a wear-constant friction value for operating temperatures up to about 300 °C.

When this temperature is exceeded, the co-efficient of friction decreases and 'fade' is said to occur. As applied to brakes, fade results in an increase in the pedal force and in cases where the brakes have become over heated, the driver experiences difficulty in stopping the vehicle.

The graph below shows the effects of temperature on two different brake materials. Tests are performed by the manufacturer to select a material which suits the particular vehicle.

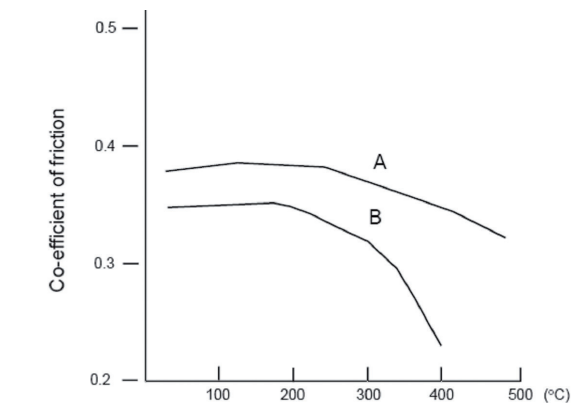

Effects of Temperature on Brake Linings (Lining A fades at a higher temperature than does B).

List of some asbestos-free friction materials currently used in the vehicle braking systems;

- Glass fibre
- Kevlar
- Ceramics

Typical coefficient of friction for brake materials is 0.4.

5.0 Factors Affecting Braking/Stopping Distances

Key Learning Points

- Factors affecting braking/stopping distances (tyre and road conditions, driver's reaction, condition of brake system etc.)

5.1 Factors Affecting Braking/Stopping Distances

Tyre and road conditions, driver's reaction, condition of brake system, type of braking system e.g. anti lock brakes, Load on the wheel during stopping, suspension condition.

6.0 Principles of Operation of the Drum Brake System

Key Learning Points

- Principles of operation of the drum brake system (including component identification, shoe lining friction materials, drum materials, heat dissipation, riveted and bonded linings, return springs, wheel cylinder, adjustment mechanisms etc.).

6.1 Drum Brake

Drum brakes have a drum attached to the wheel hub and braking occurs by means of brake shoes, expanding against the inside of the drum. A drum brake is a brake in which the friction is caused by a set of shoes or pads that press against the inner surface of a rotating drum. The drum is connected to a rotating wheel.

The shoes in drum brakes are subject to wear and the brakes needed to be adjusted regularly. Self adjusting brakes operate by a ratchet mechanism engaged as the hand brakes are applied. If the travel of the handbrake actuator lever exceeds a certain amount, the ratchet turns an adjuster screw that moves the brake shoes toward the drum.

6.2 Drum Brake Operation

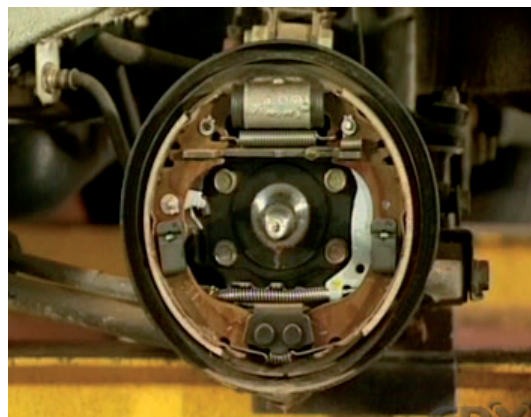

They can be expanded mechanically, or hydraulically. The main advantage claimed for drum brakes is that the shoe mountings can be designed to assist their own operation. This is called self-energizing.

Less hydraulic pressure is then needed to stop the vehicle, which is why many older drum-braked vehicles didn't use a brake booster.

The main disadvantage of drum brakes is that the friction area is almost entirely covered by lining, so most heat must be conducted through the drum to reach the outside air to cool. With hard use, this can cause overheating and eventually Brake Dissolve. Brake Dissolve is the gradual loss of brake stopping power during prolonged or strenuous use (brake fade). Very high temperatures occur at the brake drum and that causes deterioration in the frictional value of the lining or pad material. It's common in drum brakes.

Another problem with drum brakes is that it is difficult to get water out of the drum. If a vehicle is driven through water it takes longer to get the brakes working effectively.

Three brake designs are in general use:

- Single leading shoe
- Twin leading shoe
- Duo-servo

Each one uses the wedging or self-energizing action of the brake shoe, to assist the lining to grip the rotating drum when the brakes are applied.

The single leading shoe system uses a single wheel cylinder with 2 pistons. When the brakes are applied, both shoes press against the brake drum. One shoe is called leading shoe, the other is called trailing. The leading shoe tends to be self-energised, while the trailing shoe tends to be forced off the drum. This arrangement is common on rear wheels as they work equally well in forward and reverse, so it makes an effective handbrake. They can also have a self-adjusting mechanism.



The twin-leading shoe has an actuator for each brake shoe. The actuator can be mechanical; however a hydraulic actuator is popular on light vehicles. The hydraulic actuator is called the wheel cylinder. This arrangement has 2 wheel cylinders, with 1 piston in each cylinder. When the brakes are applied hydraulic pressure forces each piston to move outwards, pushing on one end of the brake shoe. The direction of rotation of the drum produces a wedging action on both brake shoes, so they are both called leading shoes.

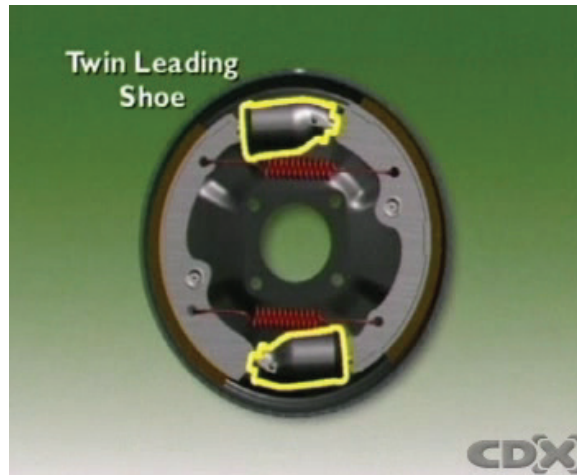

This system was once popular on front wheels because it is very efficient in the forward direction. This is due to the self-energizing /self servo or self-wedging action of the shoes as the drum rotates.

Its main disadvantage is that it is only about 30% as efficient in reverse it is usually combined with a single leading shoe arrangement on the rear to provide a balanced system.

The duo-servo design also uses 1 wheel cylinder with 2 pistons. It is a high energy brake, that is, it exerts large self-energising forces. The lower ends of the shoes are linked but aren't firmly anchored to the backing plate. This lets the complete shoe assembly float within limits. When the brakes are applied both shoes are carried around by the drum until the secondary shoe contacts the anchor pin. The self-energizing force of the primary shoe and its wheel cylinder application force are now transferred to the secondary shoe through the lower linkage. Force is then being applied to the secondary shoe from both ends - the wheel cylinder at the top and the linkage from the primary shoe at the bottom. The primary shoe has the shorter lining and is always fitted ahead of the wheel cylinder in terms of drum rotation. It's most important that the shoes are fitted correctly since it's the secondary shoe that does most of the work. The linings

may also have different frictional values. The colours of the retraction springs indicate different spring strengths. This design is common on rear wheels and it works well in both directions.

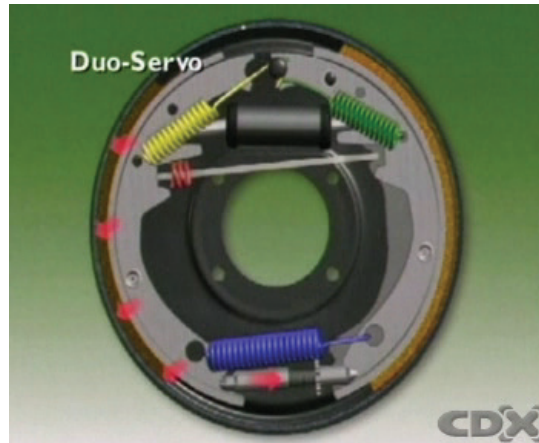

Drum brake systems need to be adjusted to allow for wear of the lining. If they are not adjusted pedal travel will be too long to be safe.

6.3 Drum Brake Components

Drum brakes are still found on older vehicles and on cars with a combination of both disc and drum brakes.

The main components of the drum brake system are:

- Backing plate
- Brake drum & brake shoe assembly
- Wheel cylinder
- Retaining clips & springs
- Automatic brake self-adjuster

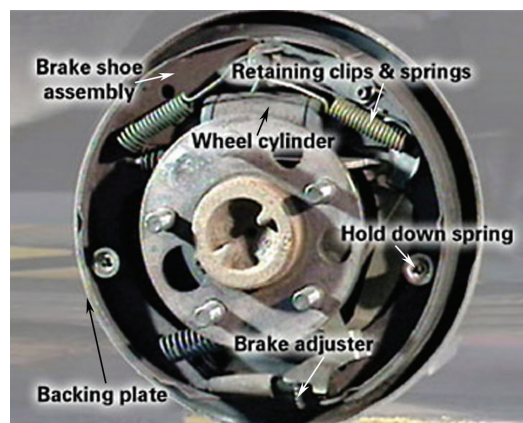

Brake Drum & Brake Shoe Assembly

The brake drum fits over the brake linings and forms the braking surface for these linings.

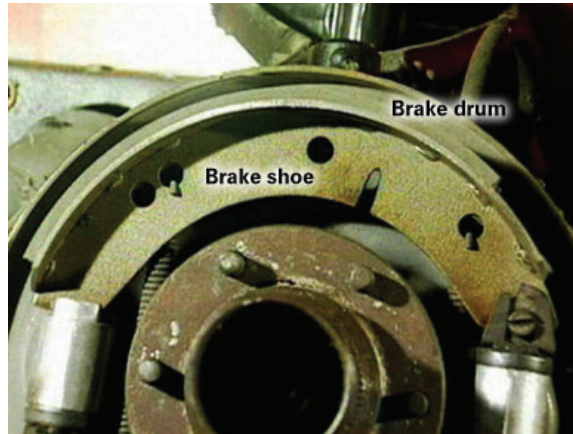

The brake shoe assembly consists of the steel shoe and the brake lining material.

Retaining Clips & Springs

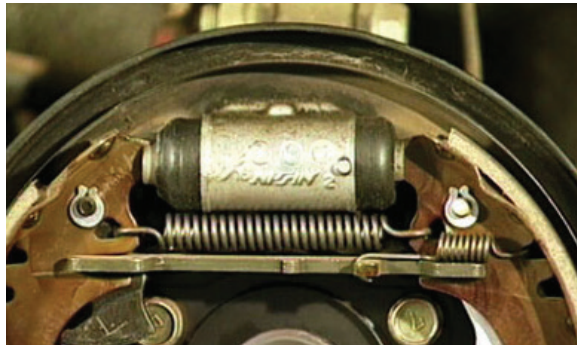

The brakes are held against the backing plate by retaining clips and springs.

The hold down spring is used to retain the brake shoe in position in relation to the backing plate. During vehicle operation it keeps the brake shoe in position.

Automatic Brake Self-Adjuster

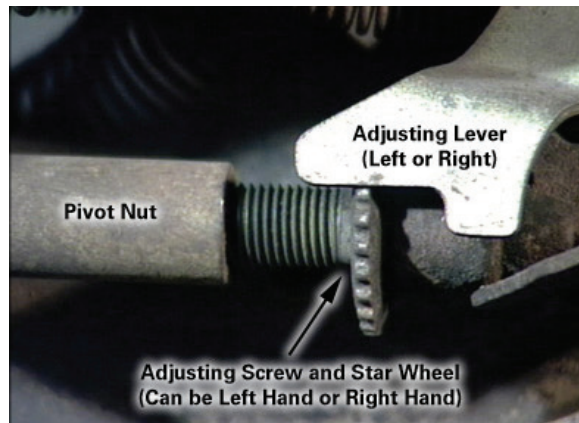

To manually adjust the brakes it may be necessary to release the adjusting lever away from the star wheel. To do this, insert a small screwdriver through the adjust slot in the backing plate and push on the adjusting lever. A brake adjuster can now be used to adjust the brakes in the usual way.

6.4 Backing Plate

All of the brake unit components, except the brake drum, are mounted on a backing plate bolted to the vehicle axle housing or suspension.



The backing plate is usually pressed from heavy gauge steel. It has a raised outer edge that fits into a groove or recess in the brake drum and helps keep out any dust or dirt.

Some vehicles have manual brake adjusters so openings are usually provided to allow for adjustments without having to remove the wheel and brake drum.

6.5 Wheel Cylinders

The wheel cylinder is located inside the brake drum and bolted to the backing plate. It converts hydraulic pressure from the master cylinder into mechanical force that pushes the brake linings against the brake drum.



Wheel cylinders are either:

- Single piston/single action; and
- Dual action/double cylinder with a piston at each end.

They are usually made of cast iron or aluminium alloy. Some are sleeved with stainless steel to be longer-wearing and more resistant to corrosion. Cast iron and aluminium cylinders are susceptible to pitting and potential fluid loss if the brake fluid is contaminated particularly with water vapour. This also lowers the boiling point of the brake fluid.

6.6 Brake Linings & Shoes

The drum brake uses brake shoes that have friction material called linings attached to them. This friction material was once made of asbestos but concerns about health problems associated with asbestos have led to increasing use of non-asbestos alternatives. Linings can be riveted or more often bonded to the brake shoes.



The composition of the friction material affects brake operation. Linings which provide good braking with low pedal pressures tend to lose efficiency when they get hot. This means the stopping distance will be increased.

Linings which maintain a stable friction co-efficient over a wide temperature range generally require higher pedal pressures to provide efficient braking. This may necessitate the use of a brake servo/booster.

WARNING!

Asbestos in brake components

Beware many older brake pads and linings were constructed with asbestos in the material. Asbestos fibbers are a known health risk that can lead to lung diseases after many years of exposure. As the linings or pads worn down asbestos fibbers were present and could easily be inhaled. Reputable manufacturers have ceased using asbestos in their linings. Most governments around the world have now legislated against the inclusion of asbestos in new brake linings. It is virtually impossible to know if asbestos has been used. In this case all brake lining servicing should be carried out as though there is asbestos in the material.

Cleaning methods can vary from using special vacuum cleaners to a washing method of remove the brake dust. *As a matter of importance never use an air hose to blow dry dust off any brake component.*

7.0 Brake Shoe Arrangements

Key Learning Points

- Distinction between brake shoe arrangements (leading/leading and leading/trailing arrangements, front/rear application, single/double acting wheel cylinders)

Text covered in section 6.0

8.0 The Term 'Self-Servo Action' as Applied to Drum Brakes

Key Learning Points

- Definition of the term 'self-servo action' as applied to drum brakes

8.1 Self Servo Action

The term Self Servo Action is the Self Servo/Self-Energizing or Self-Wedging Action of the Shoes as the Drum Rotates

9.0 Servicing Drum Brake Assembly

Key Learning Points

- Drum brake dismantling (including manufacturer's recommended procedures for drum/bearing/shoe removal)
- Drum brake component cleaning/examination and comparison to recommended specifications (including lining/return spring/wheel cylinder external condition, measurement of drum internal wear etc.)
- Refitting/replacement of drum brake components and reassembly (including manufacturer's recommended shoe and bearing lubrication/adjustment procedure, re-torque wheels to manufacturer's specification, pumping and checking brake pedal pressure prior to road test, fluid level check etc.)

Practical Task

This is a practical task. Please refer to your instructor for additional information, which is available from the automotive technical manuals.

10.0 Principles of Operation of the Disc Brake System

Key Learning Points

- Principles of operation of the disc brake system (including component identification, piston retraction principle when brakes are released, pad lining friction materials, anti-rattle devices, wear indicators, disc materials, heat dissipation, calliper types etc.)

10.1 Disk Brake Operation

Disc brakes can be used on all 4 wheels of a vehicle or combined with disc brakes on the front wheels and drum brakes on the rear. When the brake pedal is depressed a push rod transfers the force through a brake booster to a hydraulic master cylinder. The master cylinder converts the force into hydraulic pressure, which is then transmitted via connecting pipes and hoses to one or more pistons at each brake calliper. The pistons operate on friction pads to provide a clamping force on a rotating flat disc that is attached to the wheel hub. This clamping tries to stop the rotation of the disc and the wheel.

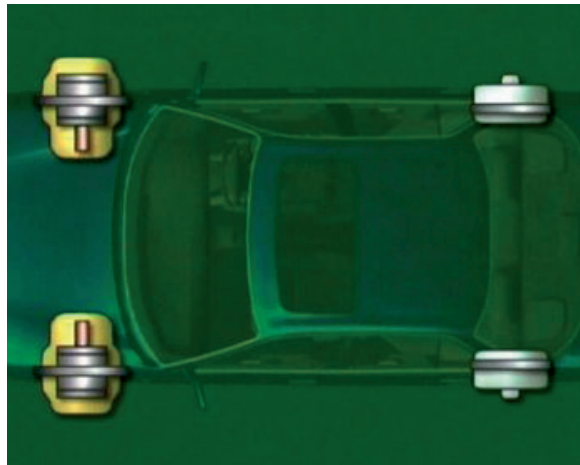

On non-driving wheels the centre of the brake disc or hub contains the wheel bearings. The hub can be part of the brake disc or a separate assembly between the wheel and hub with nuts or bolts. On driving wheels the disc is mounted onto the driving axle and may be held in place by the wheel. On front wheel drive vehicles, it can be mounted on the front hub and wheel bearing assembly.

The brake calliper assembly is bolted to the vehicle axle housing or suspension.

In most cases the brake is positioned as close as possible to the wheel, but there are exceptions. Some high-performance cars use inboard disc brakes on its rear wheels. The makers claim improved vehicle handling for this design because it reduces unsprung weight.

Applying brakes can absorb a lot of vehicle energy so friction between braking surfaces generates great heat. Brake parts withstand very high temperatures. Most of the friction area of a disc is exposed to air so cooling is far more rapid than for a drum brake. Unlike with drum brakes brake fade is rare.

Definition: Brake fade is the loss of braking efficiency due to excessive heat.

Because of their shape, discs tend to throw off water. So after being driven through water, they operate almost immediately.

Disc brakes need much higher pressures to operate than drum brakes, so almost all disc brake systems need a power brake booster to help reduce the pedal forces that are needed from the driver.

Because of the high forces needed to apply a disc brake, using it as a handbrake is less common. Some vehicles build a drum brake into the centre of the rear disc to provide for park brake operation.

Mechanism

Pressurized brake fluid travels along the brake line to the calliper. The pressurized fluid pushes the piston and inner brake pad against the disc. Pressure against the disc pushes the calliper away from the piston, pulling the outer brake pad against the disc. As the brake pads clamp together, friction slows the rotation of the disc and wheel.

Discs

The design of the disc varies somewhat. Some are simply solid steel, but others are hollowed out with fins joining together the disc's two contact surfaces (usually included as part of a casting process). This "ventilated" disc design helps to dissipate the generated heat.

Disc Damage

Discs are usually damaged in one of three ways:

- Warping,
- Scarring
- Cracking.

In addition, the useful life of the discs may be greatly reduced by excessive machining.

Warping

Warping is caused by excessive heat build up, which softens the metal and can allow it to be disfigured. This can result in wheel shimmy during braking. The likelihood of warping can be reduced if the car is being driven down a long grade by several techniques.

Scarring

Scarring can occur if brake pads are not changed promptly, all the friction material will wear away and the calliper will be pressed against the metal backing, reducing braking power and making scratches on the disc. For this reason it is prudent to periodically inspect the brake pads for wear (this is done simply on a vehicle lift when the tires are rotated without disassembly of the components). When practical they should be replaced before the pad is completely worn.

Cracking

Cracking is limited mostly to drilled discs, which get small cracks around the drilled holes. These cannot be repaired.

Callipers

The brake calliper is the assembly which houses the brake pads and pistons. The pistons are usually made of aluminium or chrome plated iron. There are two types of callipers: floating or fixed. A fixed calliper does not move relative to the disc. It uses one or more pairs of pistons to clamp from each side of the disc and is more complex and expensive than a floating calliper. A floating calliper (also called a "sliding calliper") moves with respect to the disc; a piston on one side of the disc pushes the inner brake pad till it makes contact with the braking surface, then pulls the calliper body with the outer brake pad so pressure is applied to both sides of the disc.

Floating calliper (single piston) designs are subject to failure due to sticking. This can occur due to dirt or corrosion if the vehicle is not operated. This can cause the pad attached to the calliper to rub on the disc when the brake is released. This can reduce fuel mileage and cause excessive wear on the affected pad.

Pistons & Cylinders

The most common calliper design uses a single hydraulically actuated piston within a cylinder. Some high performance brake systems may use as many as 8. Modern cars use different hydraulic circuits to actuate the brakes on each set of wheels as a car safety measure. The hydraulic design also helps multiply braking force.

Failure can occur due to failure of the piston to retract - this is usually a consequence of not operating the vehicle during a time that it is stored outdoors in adverse conditions. For high mileage vehicles the piston seals may leak, which must be repaired quickly.

Brake Pads

The brake pads are designed for high friction with the disc while wearing evenly. The brake pads must be replaced regularly and most are equipped with a method of alerting the driver when this needs to take place (wear indicator). Some have a thin piece of soft metal that causes the brakes to squeal when the pads are too thin while others have a soft metal tab embedded in the pad material that closes an electric circuit and lights a warning light when the brake pad gets thin. More expensive cars may use an electronic wear sensor.

Parking Brakes

Most vehicles include a mechanical parking brake system (also called an "emergency brake") which operates on the rear wheels.

Materials Advances

Recently carbon-ceramic and carbon-carbon composite brakes have been used in racing cars. Carbon-carbon brake discs are composed of carbon fiber within a carbon matrix exploiting the excellent thermal conductivity of graphite.

10.2 Disk Brake Rotors (Brake Disk)

The brake disc or rotor is the main rotating component of the disc brake unit. It's usually made of cast iron because it's hard-wearing and can resist high temperatures.

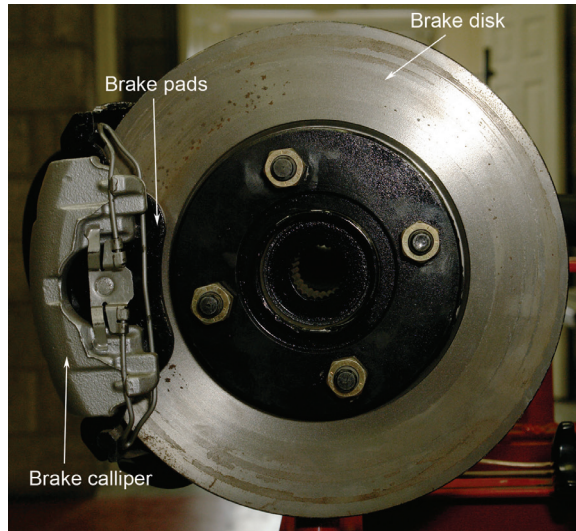

Most brake discs are stamped with the manufacturer's minimum thickness specification. When the pad wears if the thickness of the disc were below this minimum the piston may go beyond the sealing edge.

Ventilated discs can be used to improve cooling. These slots are designed to use centrifugal force to cause airflow when the disc is rotating. Some discs are drilled or slotted on their friction surface to improve cooling and assist with removing water.

10.3 Disk Brake Pads

Friction Materials

The lining material is the most important aspect of any braking system. They are variations in the composition and quality levels. Disc brake pads consist of friction material bonded onto a steel backing plate. The backing plate has lugs that locate the pad in the correct position in relation to the disc.

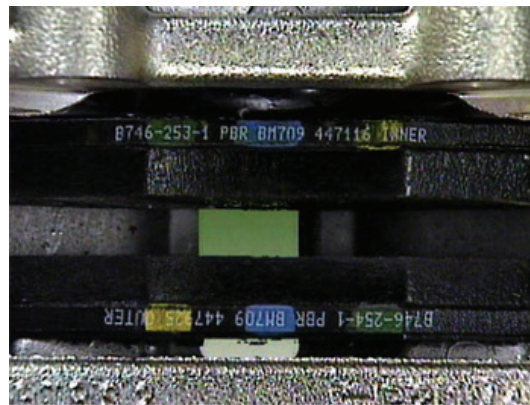

Callipers are usually designed so that the condition of the pads can be checked easily once the wheel has been removed and to allow the pads to be replaced with a minimum of disassembly. Some pads have a groove cut into the friction surface. The depth of this groove is set so that when it can no longer be seen the pad should be replaced.

Some pads have a wire in the friction material at the minimum wear thickness. When the pad wears to this minimum thickness, the wire touches the disc as the brakes are applied. A warning light then tells the driver the disc pads are due for replacement.

The composition of the friction material affects brake operation. Materials which provide good braking with low pedal pressures tend to lose efficiency when they get hot. This means the stopping distance will be increased.

Materials which maintain a stable friction co-efficient over a wide temperature range generally require higher pedal pressures to provide efficient braking.

10.4 Disk Brake Callipers

The disc brake calliper assembly is bolted to the vehicle axle housing or suspension.

There are 2 main types: *Fixed and Sliding*.

Fixed callipers can have 2, 3, or 4 pistons. 2-piston callipers have one piston on each side of the disc. Each piston has its own disc pad. When the brakes are applied hydraulic pressure forces both pistons inwards causing the pads to come in contact with the rotating disc.

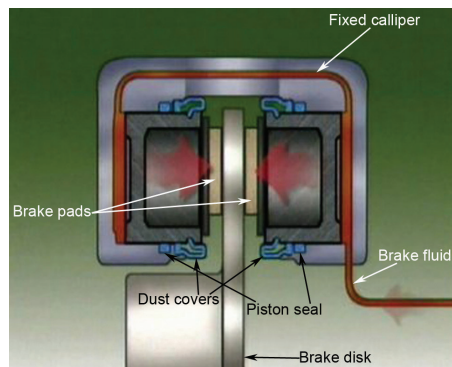

Fixed Brake Calliper

The *sliding or floating calliper* has 2 pads but only 1 piston. The calliper is mounted on pins or bushes that let it move from side to side. When the brakes are applied, hydraulic pressure forces the piston inwards. This pushes the pad against the disc. The calliper is free to move on slides so there is a clamping effect between the inner and outer pads. Equal force is then applied to both pads which clamp against the disc.

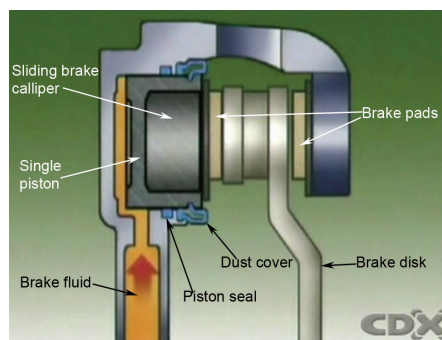

Sliding brake calliper

In disc brake callipers, the piston moves against a stationary square section sealing ring. When the brakes are applied, the piston slightly deforms the seal.

When the brakes are released, the seal returns to its original shape. The action of this sealing ring retracts the piston to provide a small running clearance between the disc and pads. It also makes the brake self-adjusting.

11.0 The Term 'Brake Fade'

Key Learning Points

- Definition of 'brake fade'

11.1 Brake Fade

In automobiles fade or brake fade is the reduction in stopping power caused by a build-up of heat in the braking surfaces (and in the case of drum brakes the change in dimension of components in response to heat). It occurs most often during high performance driving or when going down a long, steep hill. Owing to their configuration this is more prevalent in drum brakes. Disk brakes are much more resistant to brake fade and have come to be a standard feature in front brakes for most vehicles but the brake rotors can become warped due to excessive heating.

Brake fade and rotor warping can be reduced through proper braking technique; When running down a long downgrade that would require braking simply select a lower gear (for automatic transmissions this may necessitate a brief application of the throttle after selecting the gear). Also periodic rather than continuous application of the brakes will allow them to cool between applications. Continuous light application of the brakes can be particularly destructive in both wear and adding heat to the brake system.

12.0 Servicing Disc Brake Assembly

Key Learning Points

- Disc brake dismantling (including manufacturer's recommended procedures for pad/disc removal)
- Disc brake component examination and comparison to recommended specifications (including lining/anti-rattle device/calliper external condition, measurement of disc wear etc.)
- Refitting/replacement of disc brake components and reassembly (including prevention of brake fluid overspill from reservoir, manufacturer's recommended calliper piston retraction procedure, wheels retorqued to manufacturer's specification, pumping and checking brake pedal pressure prior to road test, fluid level check etc.)

Practical Task

This is a practical task. Please refer to your instructor for additional information, which is available from the automotive technical manuals.

13.0 Comparing Disc and Drum Brake Systems

Key Learning Points

- Comparison between disc and drum brake systems (advantages and disadvantages of each)

13.1 Advantages and Disadvantages of Disk/Drum Brakes

Advantages

| <i>Disc Brake</i> | <i>Drum Brake</i> |
|--|-----------------------------------|
| (A) Greater heat dissipation | (A) Self-applying action |
| (B) Cleaner braking surface (Centrifugal force throws water and dirt off disc) | (B) Simple hand brake arrangement |
| (C) Lighter in weight | |
| (D) Simple construction and easier service | |
| (E) Self adjusting | |

Disadvantages

| Disc Brake | Drum Brake |
|---|--|
| (A) No self-applying action higher operating force required | (A) Brake fade |
| (B) Complicated hand brake design mechanism required | (B) Need for adjusting (some drum brakes are self adjusting but are of complicated design) |
| | (C) Brake inspection requires removal of parts |

14.0 The Use of Brake Pedal as a Lever

Key Learning Points

- Brake pedal leverage (including clockwise/anticlockwise moments, mechanical brake force ratio)

14.1 Brake Pedal

The brake pedal uses leverage to transfer the effort from the driver's foot to the master cylinder.

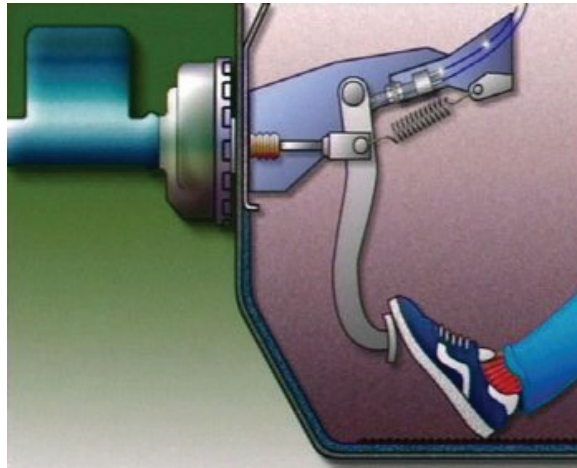

Different lever designs can alter the effort the driver needs to make. This is achieved by the utilization of mechanical advantage. This uses a second order lever to gain its mechanical advantage or ratio.

Problems That Can Be Identified From the Pedals

Pedal pulsation, excessive pedal travel, a “soft” or “hard” pedal can be indicators of serious problems, including a leak in the hydraulic system, low fluid levels, or unevenly worn shoes or pads. For Vehicles fitted with ABS brakes: it can be reassuring to feel that brake pedal pulsating beneath the foot during a full brake application is not a reason to suspect a potential problem. If the driver is getting the same pedal pulsation with a light to medium braking application a possible problem is with the ABS sensor circuit.

Brake Light Switching

In many vehicles the brake pedal is either connected to a switch or in contact with one. It operates the stop lights when the brake pedal is depressed. On modern engines it is also connected to vehicle engine management systems.

Important

If there is any change in the "feel" of your brake pedal when applied in its normal mode. This could signal a potentially serious fault developing in the hydraulic system.

14.2 Brake Pedal Leverage

The driver effort can be greatly increased at the brake shoes by the combination of pedal leverage which is converted into pressure by the master cylinder and further increased by using larger diameter wheel cylinders or callipers.

Force divided by Area = Pressure and if area is increased then force is increased. This is achieved at the expense of travel. If the force is increased the travel is decreased in proportion.

Mechanical Factor

When brakes are applied on a vehicle the force from the driver's foot is multiplied by a system of levers which in turn is multiplied by the hydraulic system to give a force ratio of about 20:1

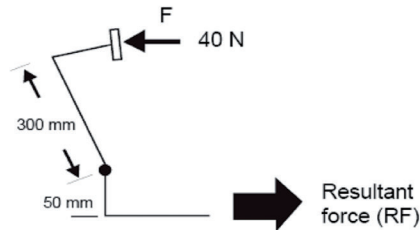

$$\text{Mechanical factor} = \frac{300}{50} = 6:1$$

$$\text{R.F.} = 6 \times 40 = 240 \text{ N}$$

This can also be done by moments

$$\text{Clockwise moment} = \text{Anti-clockwise moment}$$

$$(\text{CM}) = (\text{ACM})$$

$$50 \times \text{RF} = 300 \times 40$$

$$= \frac{300 \times 40}{50}$$

$$\text{RF} = 240 \text{ N}$$

15.0 Mechanical Handbrake used with a Drum Brake System

Key Learning Points

- Function and principles of operation of the mechanical handbrake used with a drum brake system

15.1 Parking Brakes



All vehicles must have at least two independent systems. They were once called the service brake (park brake) and emergency brake. Now they are usually referred to as the foot brake and the park brake. Most light vehicles use a foot-brake that operates through a hydraulic system on all wheels and a hand-operated brake that acts mechanically on the rear wheels or on some modes front wheels. One common use of the hand-brake system is to hold the vehicle when it is parked. The systems are designed to be independent so that if one fails the other is still available.

16.0 Adjust the Handbrake Mechanism

Key Learning Points

- Handbrake mechanism adjustment using the manufacturer's recommended procedures and settings

Practical Task

This is a Vehicle specific task. Please refer to your instructor for additional information, which is available from the automotive technical manuals.

17.0 NCT/DoT VTM Requirements

Key Learning Points

- Current NCT/DoT VTM requirements for the Mechanical Brake Components and Mechanical Brake Hand Lever

17.1 NCT Requirements

Please refer to item 51 and 52 of NCT manual 2004.

18.0 NCT/DoT VTM Requirements

Key Learning Points

- Examination of the Mechanical Brake Components and Mechanical Brake Hand Lever of automotive vehicles for compliance with current NCT/DoT VTM requirements
- Use of data manuals/manufacturer's manuals/NCT/DoT VTM manual

Practical Task

This is a practical task. Please refer to your instructor for additional information, which is available from the automotive technical manuals.

Self Assessment

Q1: When filling the master cylinder with brake fluid, you must: (Tick ONE box only)

- 1. Only use the brand recommended by the vehicle manufacturer
- 2. Make sure that the correct grade or DOT type of fresh fluid is used
- 3. Make sure you wipe off any brake fluid that you may have spilt on the paintwork
- 4. All of the above

Q2: The major components of a disc brake assembly are: (Tick ONE box only)

- 1. Disk, calliper, disc pads
- 2. Brake drum, calliper, disc pads
- 3. Stator, wheel cylinder, brake lining
- 4. Rotator, wheel cylinder, brake lining
- 5. None of the above

Q3: The effectiveness of the braking forces is determined by: (Tick ONE box only)

- 1. Tire to road friction
- 2. Tire to road contact
- 3. Road conditions
- 4. Tire conditions

Q4: Technician A says that disc brakes require return springs. Technician B says that disc brakes do not require return springs. Who is correct? (Tick ONE box only)

- 1. Technician A
- 2. Technician B
- 3. Both Technician A and Technician B
- 4. Neither Technician A nor Technician B

Q5: When should the brake linings be checked for serviceability? (Tick ONE box only)

- 1. Every 10,000 kilometres or 6,000 miles
- 2. Every 15,000 kilometres or 9,000 miles
- 3. Every 20,000 kilometres or 12,000 miles
- 4. At the manufacturer's recommended intervals
- 5. None of the above

Q6: The hand brake should be adjusted: (Tick ONE box only)

- 1. When it won't hold the car
- 2. Before adjusting the drum brake
- 3. After adjusting the drum brake
- 4. With a special tool

Q7: One advantage of duo-servo brakes is that they: (Tick one box only)

- 1. Can be used with a booster
- 2. Wear faster
- 3. Resist brake dissolve
- 4. Work well in both directions

Q8: The coefficient of friction between the brake pad and its disc depends on: (Tick one box only)

- 1. The materials of the pad and disc
- 2. The speed of the disc
- 3. The pressure between pad and disc
- 4. The area of the pad

Suggested Exercises

1. Use an electronic data facility to procure manufacturer's appropriate data for use with practical exercises
2. Dismantle a drum brake assembly, examine components and compare their condition to recommended specifications, refit/replace components as necessary, adjust and reassemble
3. Dismantle a disc brake assembly, examine components and compare their condition to recommended specifications, refit/replace components as necessary, adjust and reassemble
4. Adjust the handbrake mechanism using the manufacturer's recommended procedures and settings

Training Resources

- Training vehicles/training units, data manuals, manufacturer's manuals, NCT/DoT VTM manual, video/multimedia resources
- Selection of mechanical braking system components including brake pads with wear level indicators, vented and non-vented brake discs, fixed and sliding callipers, antirattle devices, riveted and bonded brake shoes, brake drums, wheel cylinders, wheel bearings, torque spanners, brake spring tools, calliper piston retraction tools, disc and drum wear measurement tools, trolley jacks, axle stands
- Eye protection, latex gloves, face masks
- Sealed supply of appropriate brake fluids etc.

Suggested Further Reading

- Advanced Automotive Diagnosis. Tom Denton. ISBN 0340741236
- Automobile Electrical and Electronic Systems (3rd Edition). Tom Denton. ISBN 0750662190
- Automotive Mechanics (10th Edition). William H. Crouse and Donald L. Anglin. ISBN 0028009436
- Bosch Automotive Electrics Automotive Electronics: Systems and Components (4th Edition). Robert Bosch. ISBN 0837610508
- Bosch Automotive Handbook (6th Edition). Robert Bosch. ISBN 1860584748
- Bosch Automotive Technology Technical Instruction booklet series (numerous titles)
- Hillier's Fundamentals of Motor Vehicle Technology: Book One (5th Edition). V.A.W. Hillier and Peter Coombes. ISBN 0748780823
- Hillier's Fundamentals of Motor Vehicle Technology: Book Two (5th Edition). V.A.W. Hillier and Peter Coombes. ISBN 0748780998
- Modern Automotive Technology. James E. Duffy. ISBN 1566376106
- Motor Vehicle Craft Studies - Principles. F.K. Sully. ISBN 040800133X
- National Car Test (NCT) Manual (Department of Transport, Vehicle Testers Manual - DoT VTM). Department of Transport
- Transmission, Chassis and Related Systems (Vehicle Maintenance and Repair Series: Level 3) (3rd Edition) John Whipp and Roy Brooks. ISBN 186152806X
- Vehicle and Engine Technology (2nd Edition). Heinz Heisler. ISBN 0340691867
- <http://www.cdxglobal.com/>
- <http://auto.howstuffworks.com/>
- <http://www.autoshop101.com/>
- <http://www.cdxtextbook.com/>
- Automotive Encyclopedia and Text Book Resource (CD version of e-textbook), Available from your instructor.

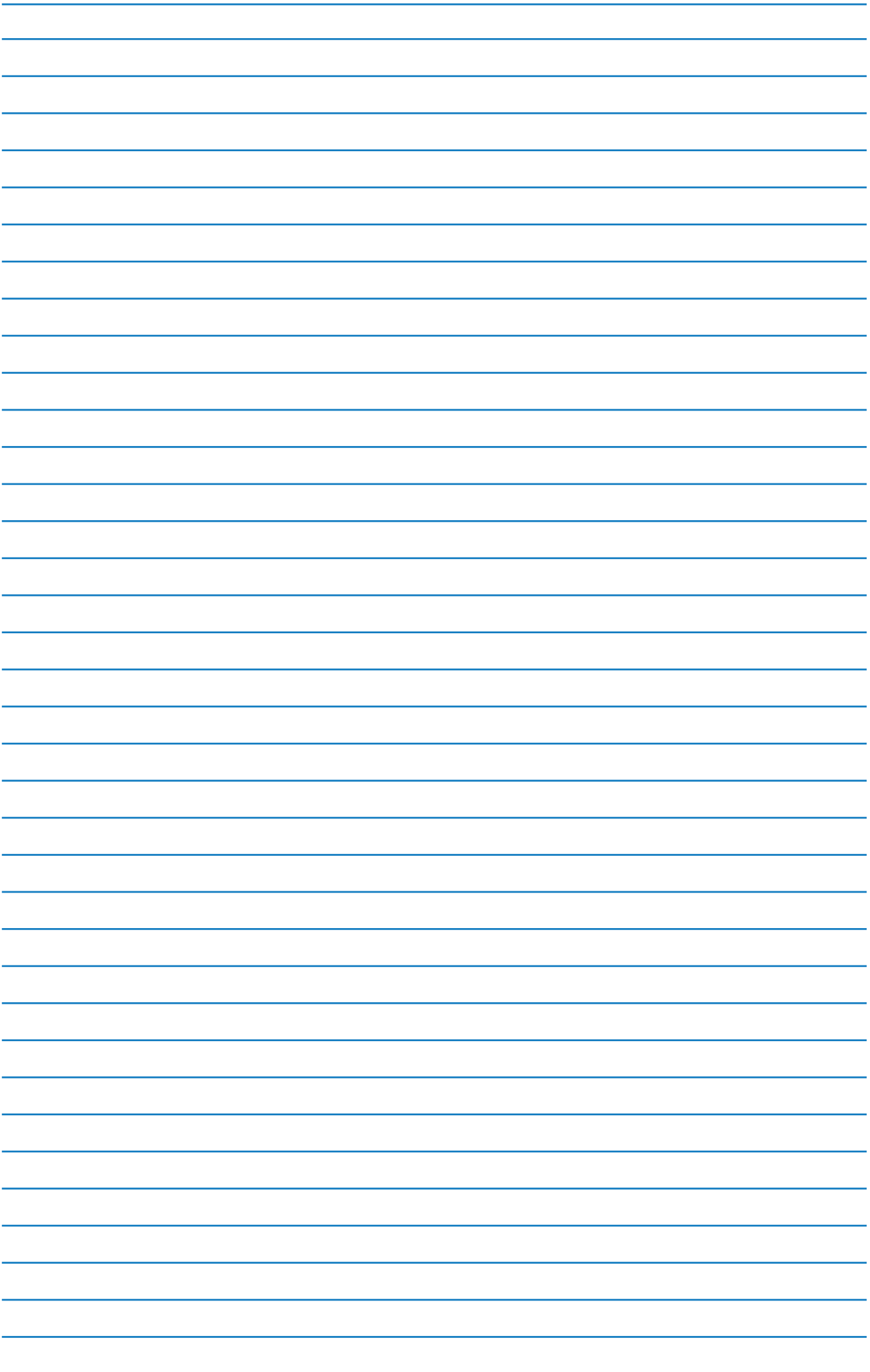

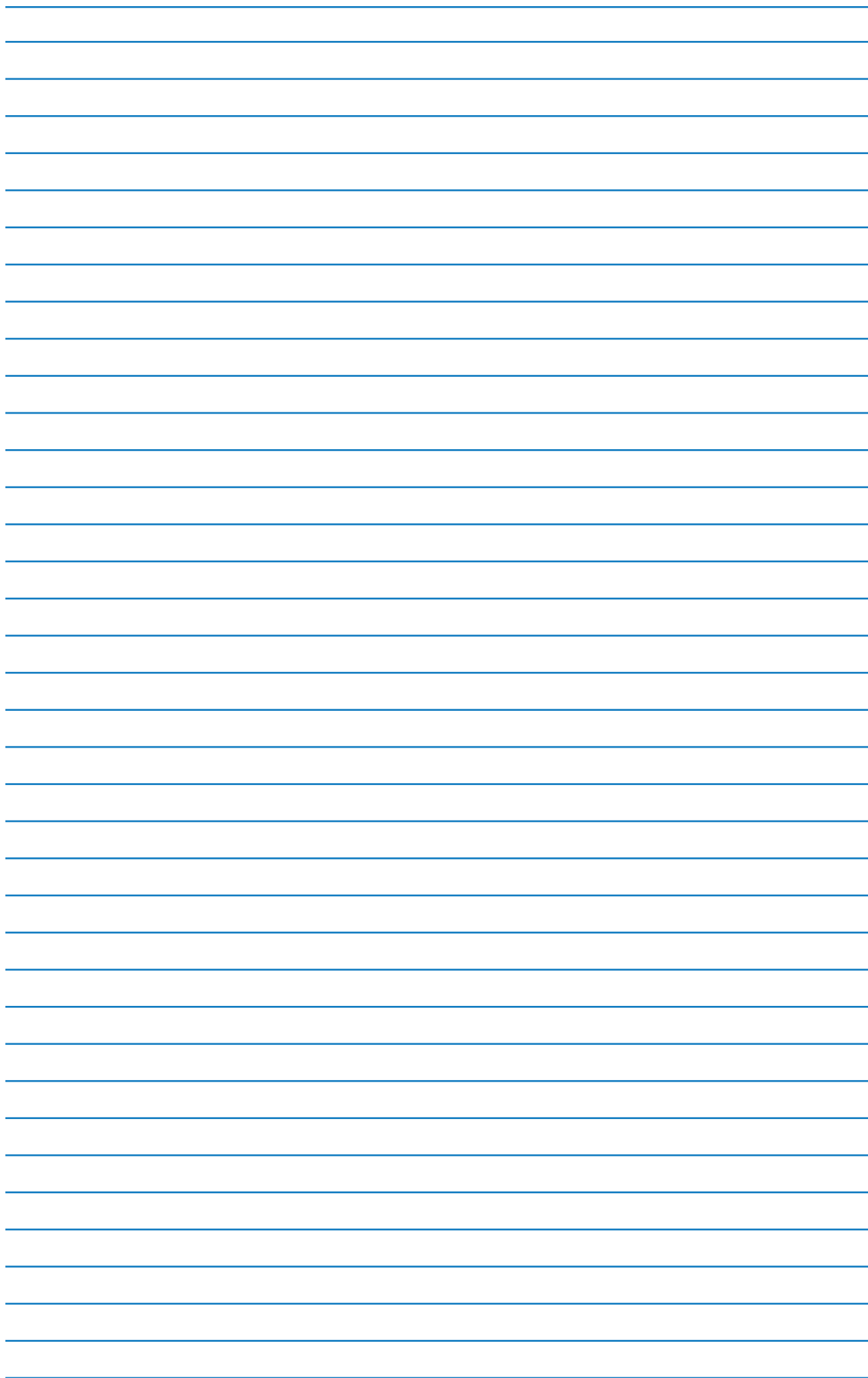

SOLAS

An tSeirbhís Oideachais Leanúnaigh agus Scileanna
Further Education and Training Authority

*27-33 Upper Baggot Street
Dublin 4*